

## Z7

### CAST BRONZE VALVE CHESTS

Suction Type - Replaceable Disc

Screwed connection rising stem valve chest/manifold, suction type, replaceable disc and outside screw.

\*Client to nominate number of sections required i.e. 1-5 (5 Sections).

#### PRESSURE/TEMPERATURE RATING

Water/Oil/Gas up to 1034KPA (150PSI)

#### OPTIONS

Each individual section has the option of Screw Down Screw Lift or Screw Down Non Return operation.

Note:

If no selection is made by the customer, Screw Down Screw Lift will always be supplied.

Modiciation made upon requests.

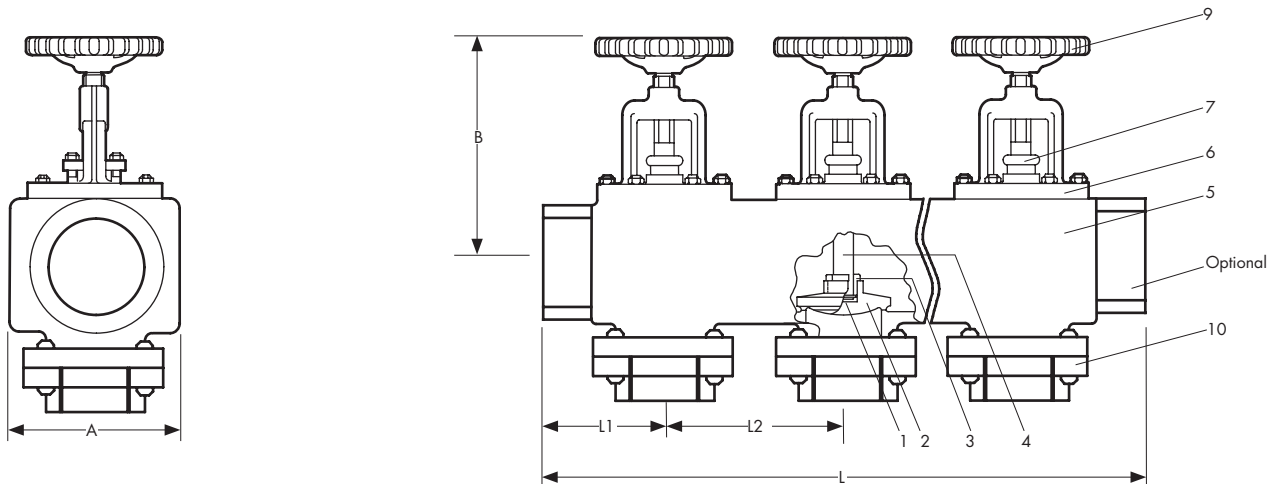

DIMENSIONS - mm				MATERIAL SPECIFICATIONS			
Size D	40	50	65	REF	Component	Material	AS or BS Specification
A	95	95	95	1	Collet	DR. Brass	AS 1567-352
B	175	175	175	2	Disc	Cast Bronze LG2	AS 1565-C83600
L1	71	71	71	3	Disc Nut	DR. Brass	AS 1567-352
L2	95	95	95	4	Spindle	DR. Brass	AS 1567-352
Mass kgs*	4.4	4.4	4.4	5	Body	Cast Bronze LG2	AS 1565-C83600
				6	Cover	Cast Bronze LG2	AS 1565-C83600
				7	Gland	Cast Bronze LG2	AS 1565-C83600
				9	Handwheel	Cast Iron	-
				10	Bottom Flange	Cast Bronze LG2	AS 1565-C83600
				11	Gasket	Klinger	K'Sil 4430
				12	Packing	PTFE	Klinger K10
				13	Fasteners	Stainless Steel	316 S/S

\* Approximate per section