

## Z3

### CAST IRON VALVE CHESTS

Suction Type - Replaceable Bronze Trim

An AS 2129 Table E flanged rising stem iron chest/manifold valve, suction type with bolted cover, replaceable bronze trim and outside screw.  
\*Client to nominate number of sections required i.e. 1-3 (3 Sections).

### PRESSURE/TEMPERATURE RATING

Water/Oil/Gas up to 1034KPA (150PSI)

### OPTIONS

Each individual section has the option of Screw Down Screw Lift or Screw Down Non Return operation.

Note:

If no selection is made by the customer, Screw Down Screw Lift will always be supplied.

Modification made upon requests.

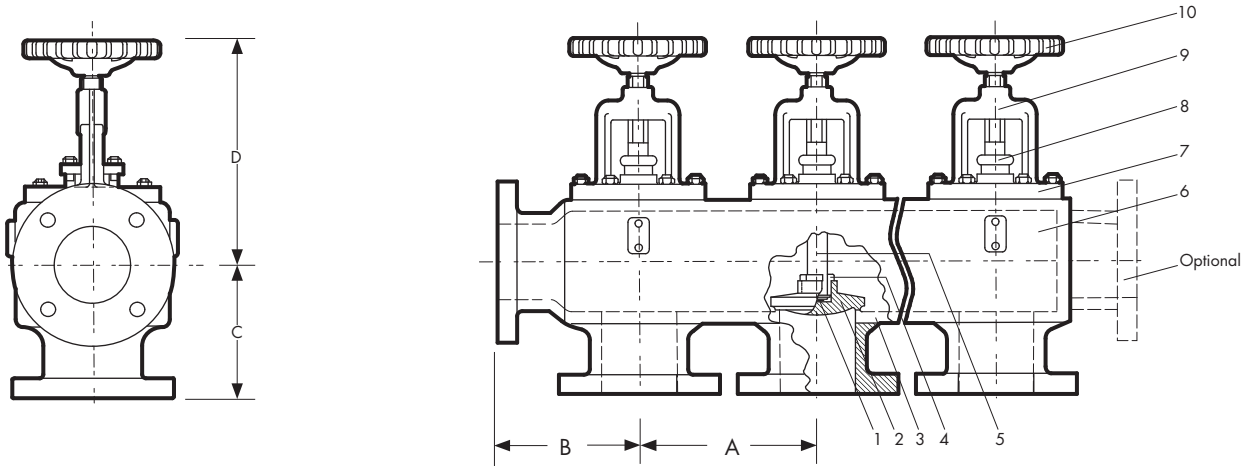

DIMENSIONS - mm			MATERIAL SPECIFICATIONS			
Size	50	65	REF	Component	Material	AS or BS Specification
A	152	190	1	Collet	DR. Brass	AS 1567-352
B	152	165	2	Disc	Cast Bronze LG2	AS 1565-C83600
C	121	137	3	Seat	Cast Bronze LG2	AS 1565-C83600
D	298	305	4	Disc Nut	DR. Brass	AS 1567-352
Mass kg#	21	28	5	Spindle	DR. Brass	AS 1567-352
<i>Note: # Mass per section.</i>			6	Body	Cast Iron	AS 1830
<i>Dimensions for larger sizes are available on request.</i>			7	Cover	Cast Iron	AS 1830
			8	Gland	Cast Bronze LG2	AS 1565-C83600
			9	Yoke Bush	DR. Brass	AS 1567-352
			10	Handwheel	Cast Iron	-
			11	Gasket	Klinger	K'Sil 4430
			12	Packing	PTFE	Klinger K10
			13	Fasteners	Stainless Steel	316 S/S