

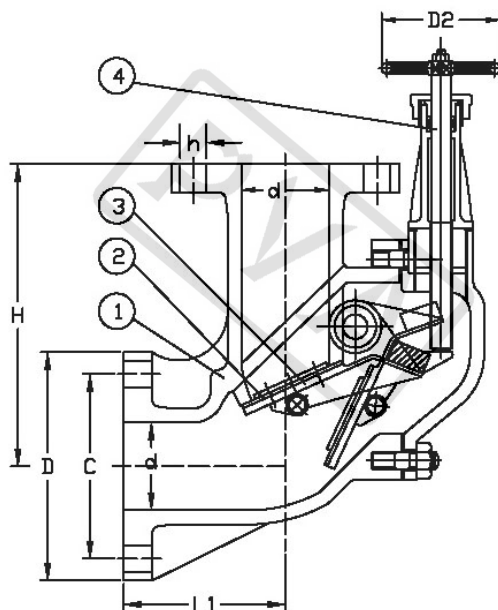

JISF3059 10K Cast Steel Angle Type Storm Valve



Pressure Test		
PN	Shell Test	Seat Test
1.0MPa	2.1MPa	1.54MPa

Main material for fittings			
Item	Fittings	Material	Mark
1	Body/Bonnet	Cast Steel	SC230~450
2	Disc	Cast Bronze	BC6
3	Seat	Cast Bronze+NBR	BC6+NBR
4	Stem	Stainless Steel/Forged Brass	SSS400/ C3771BD
5	Handwheel	Cast Iron	FC200

Main data for connection							mm
DN	Face To Face		Flange				Weight Kgs
	H	L1	Diam(D)	PCD(C)	Hole Nos(n)	Hole Diam(\varnothing h)	
50	170	90	155	120	4	19	15.29
65	200	110	175	140	4	19	22.11
80	220	120	185	150	8	19	26.51
100	250	130	210	175	8	19	38.72
125	270	150	250	210	8	23	57.97
150	310	165	280	240	8	23	69.52
200	400	190	330	290	12	23	92.07

Design	Check	Signature	Logo	Supplier
asbsey	Chrit	Figor		PROMET VALVES AUSTRALIA
JAN.01,2013	JAN.01,2013	JAN.01,2013		

PROMET VALVES AUSTRALIA

1A Green Road Woodville West SA 5011 Australia / Tel:+61 8 8268 1777 / Fax:+61 8 8268 1711
 promet@prometvalves.com / www.prometvalves.com / ABN 47 096 425 697