

Flanschen-Ausgußventil DIN-Baulänge, GG 25/Niro

mit Säulenaufsatz und Federbelastung

Öffnungsdruck einstellbar DN 15-DN 300 von 0,1-0,5 bar, DN 350-DN 500 von 0,1-0,2 bar

Outboard valve, flanged, DIN-length, cast iron/stainless steel

spring loaded, blow-off pressure: adjustable DN 15-DN 300 0,1-0,5 bar, DN 350-DN 500 0,1-0,2 bar

Nenndruck / Nominal pressure

DN 15 – DN 125 **PN16** DN 150 – DN 200 **PN10** DN 250 – DN 300 **PN 6** DN 350 – DN 500 **PN 4**

Art.Nr. 22.01.01 Form A Durchgangsform / straight type

Art.Nr. 22.01.02 Form B Eckform / angle type

Verwendungsbereich:

Geeignet für kaltes und heißes Wasser, Satt-
dampf, Öl und andere neutrale, nicht aggress-
sive Medien.

Verwendbar für Temperaturen bis 100°C

Zulässige Betriebstemperaturen und -drücke:

max. Druck	bis 100°C
DN 15 – 125	16 bar
DN 150 – 200	10 bar
DN 250 – 300	6 bar
DN 350 – 500	4 bar

Die Ventile sind gemäß den neuesten Vor-
schriften des "Germanischen Lloyd" so kon-
struiert, daß es nicht möglich ist, mittels der
Spindel das Ventil zu öffnen.

Sonderausführungen:

◇ Spindel aus CuSn 6

Application:

Suitable for cold and hot water, saturated
steam, oil and other neutral non aggressive
liquids.

Application for temperatures up to 100°C

Admissible temperatures and pressures:

max. pressure	up to 100°C
DN 15 – 125	16 bar
DN 150 – 200	10 bar
DN 250 – 300	6 bar
DN 350 – 500	4 bar

The valves are designed according to the
latest rules of the „German Lloyd“. It isn't
possible to open the valve with the stem.

Special design:

◇ Stem material CuSn 6

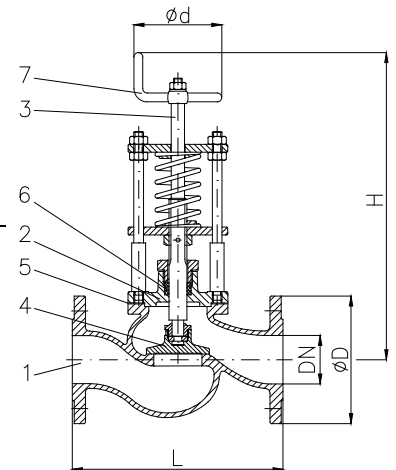

Art.Nr. 22.01.01

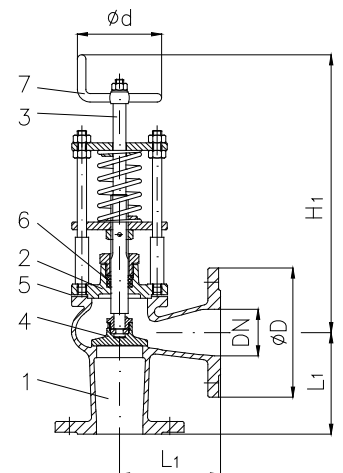

Art.Nr. 22.01.02

Teil Part	Bezeichnung Name	Werkstoff nach DIN Material acc. to DIN	Werkstoff nach BS Material acc. to BS
1	Gehäuse / body	EN-GJL-250	B.S.1452:1990 Gr.150/180
2	Deckel / bonnet	EN-GJL-250	B.S.1452:1990 Gr.150/180
3	Spindel / stem	X20Cr 13	B.S.970:1955 EN 56 C
4	Kegel / disc	X20Cr 13	B.S.970:1955 EN 56 C
5	Deckeldichtung / bonnet sealing	FA1 / asbestfrei	---
6	Dichtring / sealing ring	NBR	---
7	Handkurbel / crank handle	GTW	---

Flansch / flange										22.01.01	22.01.02
DN	Ø D	Ø k x n x Ø d1	L	L1	H	H1	Ø d	Hub		≈ kg	≈ kg
15	95	65 x 4 x 14	130	90	290	300	100	6		6,0	4,8
20	105	75 x 4 x 14	150	95	290	300	100	7		6,5	5,0
25	115	85 x 4 x 14	160	100	330	340	100	8		7,0	6,0
32	140	100 x 4 x 18	180	105	340	360	100	10		9,0	8,0
40	150	110 x 4 x 18	200	115	360	380	125	12		11,0	10,0
50	165	125 x 4 x 18	230	125	390	390	125	15		13,5	12,5
65	185	145 x 4 x 18	290	145	410	400	150	19		19,0	18,0
80	200	160 x 8 x 18	310	155	450	420	150	24		25,0	22,0
100	220	180 x 8 x 18	350	175	490	470	200	28		32,0	27,0
125	250	210 x 8 x 18	400	200	540	490	200	36		53,0	43,0
150	285	240 x 8 x 22	480	225	590	540	200	40		66,0	58,0
175	315	270 x 8 x 22	550	250	680	580	200	48		89,0	79,0
200	340	295 x 8 x 22	600	275	700	600	225	56		115,0	100,0
250	395	350 x 12 x 22	730	325	820	710	250	65		170,0	160,0
300	445	400 x 12 x 22	850	375	940	780	250	80		305,0	235,0
350	505	460 x 16 x 22	980	425	1100	1030	350	90		490,0	380,0
400	565	515 x 16 x 26	1100	475	1300	1140	350	105		530,0	420,0
450	615	565 x 20 x 26	1200	500	1500	1450	350	115		1170,0	670,0
500	670	620 x 20 x 26	1250	590	1650	1500	350	130		1320,0	820,0