

Z2NR

BRONZE GLOBE VALVE

Inside Screw - Rising Stem - Bronze Trim

An AS 2129 E flanged, rising stem cast bronze valve with inside screw, screwed cover, screw down non return and integral seat.

PRESSURE/TEMPERATURE RATING

Steam up to 700KPA (100PSI)
 Max Service Temp 170°C (338°F)
 Water, Oil or Gas up to 1400KPA (200PSI)

OPTIONS

Open and Shut Indicator.
 Locked Bonnet.
 Valve modifications and body material specification available upon request.
 # Sizes 50mm and below is fitted with an aluminium handwheel. Those 65mm and above the handwheel is cast iron.

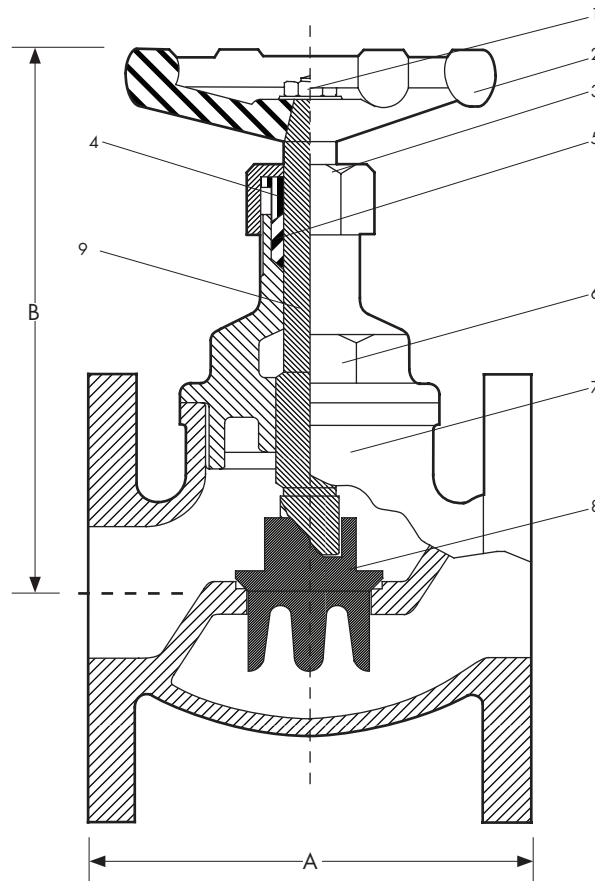

DIMENSIONS - mm								MATERIAL SPECIFICATIONS			
Size	25	32	40	50	65	80	100	REF	Component	Material	AS or BS Specification
A	89	89	105	135	165	187	203	1	Handwheel Nut	Stainless Steel	-
B	150	160	175	180	215	245	310	2	Handwheel#	Cast Iron	AS 1830
Mass kg	3.5	3.8	5.5	9	10	19	24	3	Gland Nut	DR. Brass	AS 1567-352
								4	Gland Follower	DR. Brass	AS 1567-352
								5	Packing	PTFE	Klinger K10
								6	Cover	Cast Bronze LG2	AS 1565-C83600
								7	Body	Cast Bronze LG2	AS 1565-C83600
								8	Disc	Cast Bronze LG2	AS 1565-C83600
								9	Spindle	DR. Brass	AS 1567-352

Document Version | April 2014