

## Z200NR

### BRONZE GLOBE VALVE

Outside Screw - Rising Stem - Replaceable Bronze Trim

An AS 2129 E flanged, rising stem cast bronze valve with screw down non return, outside screw, bolted cover and gland and replaceable seat and disc.

Cast integral bridge up to 200mm.

250mm and upwards in pillar and post construction.

#### PRESSURE/TEMPERATURE RATING

Steam up to 700KPA (100PSI)

Max Service Temp 170°C (338°F)

Water, Oil or Gas up to 1400KPA (200PSI)

#### OPTIONS

Open and Shut Indicator.

Valves manufactured in other flange and material specifications on request.

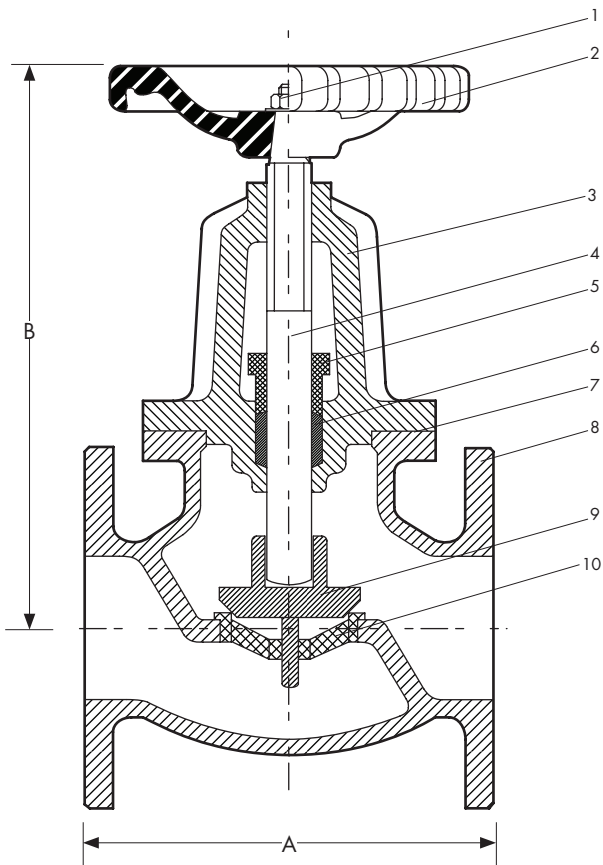

#### DIMENSIONS - mm

| Size    | 15  | 20  | 25  | 32  | 40  | 50   | 65   | 80   | 100 | 125 | 150 | 200 | 250 | 300 |
|---------|-----|-----|-----|-----|-----|------|------|------|-----|-----|-----|-----|-----|-----|
| A       | 152 | 152 | 162 | 181 | 187 | 216  | 235  | 267  | 330 | 381 | 432 | 533 | 636 | 686 |
| B       | 175 | 205 | 234 | 245 | 250 | 285  | 320  | 345  | 400 | 500 | 540 | 616 | 749 | 810 |
| Mass kg | 5   | 5.3 | 8   | 12  | 14  | 16.5 | 21.2 | 25.3 | 48  | 85  | 106 | 158 | 305 | 371 |

Dimensions for larger sizes are available on request.

#### MATERIAL SPECIFICATIONS

| REF | Component             | Material        | AS or BS Specification |
|-----|-----------------------|-----------------|------------------------|
| 1   | Handwheel Nut         | Stainless Steel | 316 S/S                |
| 2   | Handwheel             | Cast Iron       | AS 1830                |
| 3   | Cover                 | Cast Bronze LG2 | AS 1565-C83600         |
| 4   | Spindle               | DR. Brass       | AS 1567-352            |
| 5   | Gland                 | Cast Bronze LG2 | AS 1565-C83600         |
| 6   | Packing               | PTFE            | Klinger K10            |
| 7   | Cover Gasket          | Klinger         | K'Sil 4430             |
| 8   | Body                  | Cast Bronze LG2 | AS 1565-C83600         |
| 9   | Disc                  | Cast Bronze LG2 | AS 1565-C83600         |
| 10  | Seat                  | Cast Bronze LG2 | AS 1565-C83600         |
| 11  | Fasteners (not shown) | Stainless Steel | 316 S/S                |