

Z200A

BRONZE ANGLE GLOBE VALVE

Outside Screw - Rising Stem - Replaceable Bronze Trim

An AS 2129 E flanged, rising stem outside screw cast bronze valve screw down screw lift, angle pattern bolted cover and replaceable bronze seat and disc.

Cast integral bridge up to 200mm.

250mm and upwards in pillar and post construction.

PRESSURE/TEMPERATURE RATING

Steam up to 700KPA (100PSI)

Max Service Temp 170°C (338°F)

Water, Oil or Gas up to 1400KPA (200PSI)

OPTIONS

Open and Shut Indicator.

Valves manufactured in other flange and material specifications on request.

Also available as a Stop-Check Valve Screw Down Non Return (SDNR).

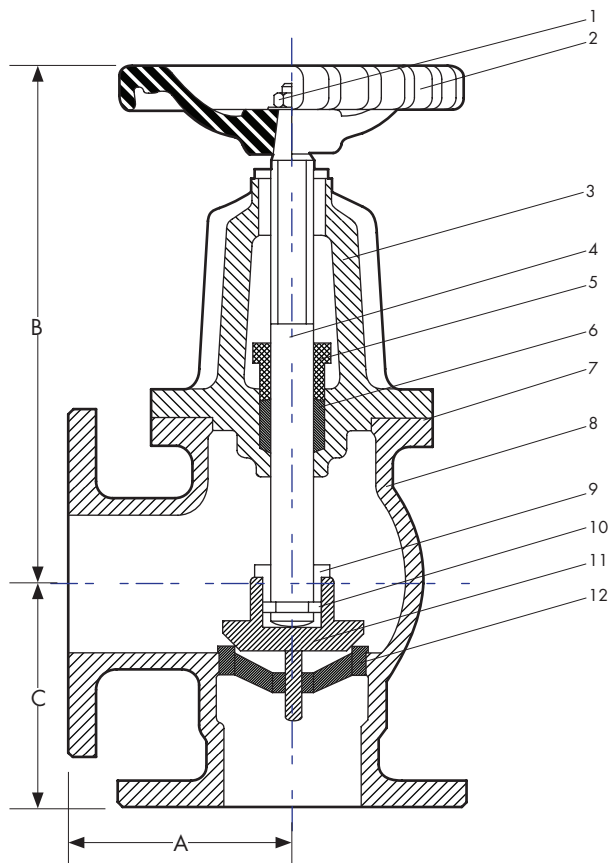

DIMENSIONS - mm

Size	15	20	25	32	40	50	65	80	100	125	150	200	250	300
A	76	76	82	90	94	108	127	140	165	190	216	241	305	330
B	171	190	218	218	220	260	280	304	345	498	455	560	622	685
C	76	76	82	90	94	108	118	140	152	176	203	229	305	330
Mass kg	4.2	4.4	6	8.5	9.6	16	18.5	27	37	65	90	145	265	329

Dimensions for larger sizes are available on request.

MATERIAL SPECIFICATIONS

REF	Component	Material	AS or BS Specification
1	Handwheel Nut	Stainless Steel	316 S/S
2	Handwheel	Cast Iron	AS 1830
3	Cover	Cast Bronze LG2	AS 1565-C83600
4	Spindle	DR. Brass	AS 1567-352
5	Gland	Cast Bronze LG2	AS 1565-C83600
6	Packing	PTFE	Klinger K10
7	Cover Gasket	Klinger	K'Sil 4430
8	Body	Cast Bronze LG2	AS 1565-C83600
9	Disc Nut	DR. Brass	AS 1567-352
10	Collet	DR. Brass	AS 1567-352
11	Disc	Cast Bronze LG2	AS 1565-C83600
12	Seat	Cast Bronze LG2	AS 1565-C83600
13	Fasteners (not shown)	Stainless Steel	316 S/S