

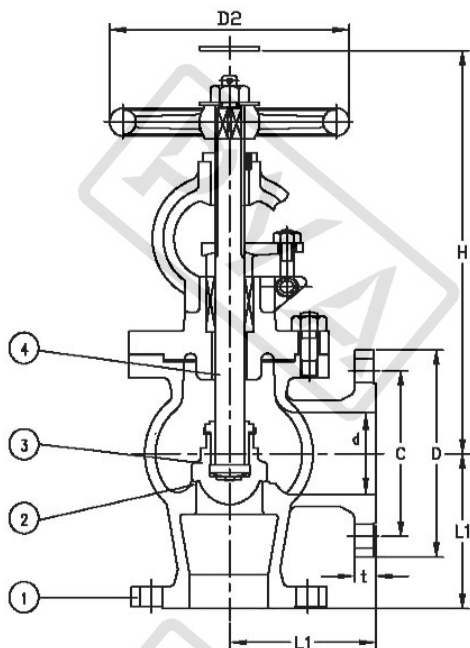

# JISF7475 30K CAST STEEL ANGLE AIR VALVE



Pressure Test MPa			
Nominal Pressure/PN	3.0MPa	Shell Test	6.90 MPa
		Seat Test	5.06 MPa

Main material for fittings			
Item	Fittings	Material	Mark
1	Body	Cast steel	SC230-450
2	Bonnet	Cast steel	SC230-450
3	Disc	Stainless Steel	SS420J1
4	Seat	Stainless Steel	SS420J1
5	Stem	Stainless Steel	SS400
6	Handwheel	Cast Iron	FC200

Main data for flange connection mm						
Model	Face To Face L	Flange Diam. D	Flange PCD C	Flange Hole n* $\phi$ d	Height H	Weight kgs
F7475 30K32	114	140	105	4 $\times$ $\phi$ 19	245	16.60
F7475 30K40	121	160	120	4 $\times$ $\phi$ 23	255	20.30
F7475 30K50	146	165	130	8 $\times$ $\phi$ 19	310	27.60
F7475 30K65	165	200	160	8 $\times$ $\phi$ 23	340	46.60
F7475 30K80	178	210	170	8 $\times$ $\phi$ 23	380	55.60
F7475 30K100	205	240	195	8 $\times$ $\phi$ 25	435	80.90
F7475 30K125	230	275	230	8 $\times$ $\phi$ 25	510	126.00
F7475 30K150	250	325	275	12 $\times$ $\phi$ 27	585	177.00
F7475 30K200	300	370	320	12 $\times$ $\phi$ 27	685	258.00

Design	Check	Signature	Logo	Supplier
asbsey	Chrit	Figor		PROMET VALVES AUSTRALIA
JAN.01,2013	JAN.01,2013	JAN.01,2013		

## PROMET VALVES AUSTRALIA

1A Green Road Woodville West SA 5011 Australia / Tel:+61 8 8268 1777 / Fax:+61 8 8268 1711  
 promet@prometvalves.com / www.prometvalves.com / ABN 47 096 425 697