

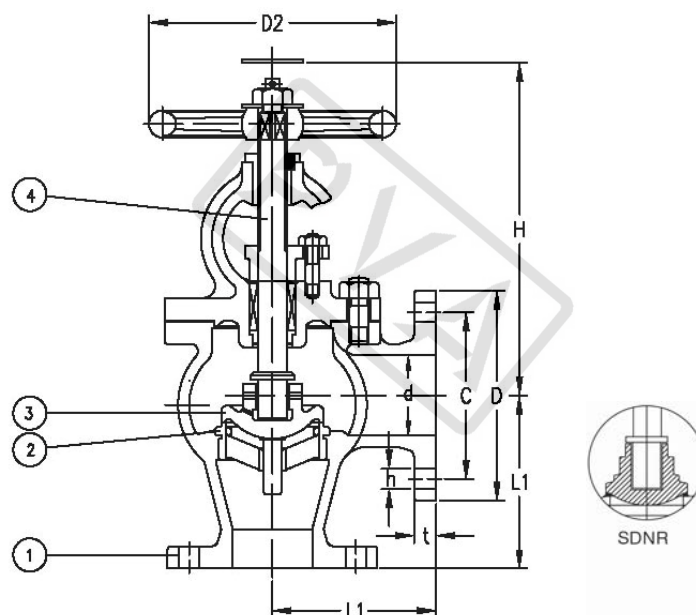

JISF7474 20K CAST STEEL SDNR ANGLE VALVE



Pressure Test MPa			
Nominal Pressure/PN	2.0MPa	Shell Test	5.0 MPa
		Seat Test	3.67 MPa

Main material for fittings			
Item	Fittings	Material	Mark
1	Body	Cast Steel	SC230~450
2	Bonnet	Cast Steel	SC230~450
3	Disc	Stainless Steel	SS420
4	Seat	Stainless Steel	SS304
5	Stem	Stainless Steel	SS400
6	Handwheel	Cast Iron	FC200

Main data for flange connection						
Model	Face To Face	Flange Diam.	Flange PCD	Flange Hole	Height	Weight
	L	D	C	n* \varnothing d	H	kgs
F7474 20K32	100	135	100	4 \times \varnothing 19	270	13.00
F7474 20K40	110	140	105	4 \times \varnothing 19	290	15.10
F7474 20K50	125	155	120	8 \times \varnothing 19	305	19.90
F7474 20K65	135	175	140	8 \times \varnothing 19	345	26.70
F7474 20K80	150	200	160	8 \times \varnothing 23	385	38.80
F7474 20K100	170	225	185	8 \times \varnothing 23	440	54.20
F7474 20K125	200	270	225	8 \times \varnothing 25	500	83.00
F7474 20K150	225	305	260	12 \times \varnothing 25	550	115.00
F7474 20K200	280	350	305	12 \times \varnothing 25	630	183.00
F7474 20K250	310	430	380	12 \times \varnothing 27	725	285.00

Design	Check	Signature	Logo	Supplier
asbsey	Chrit	Figor		PROMET VALVES AUSTRALIA
JAN.01,2013	JAN.01,2013	JAN.01,2013		

PROMET VALVES AUSTRALIA

1A Green Road Woodville West SA 5011 Australia / Tel:+61 8 8268 1777 / Fax:+61 8 8268 1711
 promet@prometvalves.com / www.prometvalves.com / ABN 47 096 425 697