

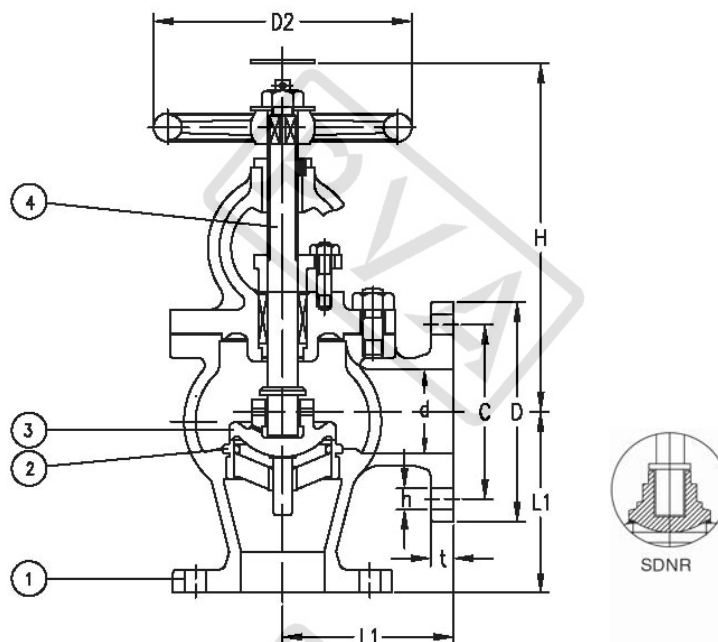

JISF7472 10K CAST STEEL SDNR ANGLE VALVE



Pressure Test MPa			
Nominal Pressure/PN	1.0MPa	Shell Test	2.1 MPa
		Seat Test	1.54 MPa

Main material for fittings			
Item	Fittings	Material	Mark
1	Body	Cast Steel	SC230~450
2	Bonnet	Cast Steel	SC230~450
3	Disc	Stainless Steel/Cast Bronze	SS420/BC6
4	Seat	Stainless Steel/Cast Bronze	SS420/BC6
5	Stem	Stainless Steel/Forged Brass	SS400/C3771BD
6	Handwheel	Cast Iron	FC200

Main data for flange connection mm						
Model	Face To Face L	Flange Diameter D	Flange PCD C	Flange Hole n* ϕ d	Height H	Weight kgs
F7472 10K50	120	155	120	4 \times ϕ 19	240	16.30
F7472 10K65	130	175	140	4 \times ϕ 19	260	23.10
F7472 10K80	140	185	150	8 \times ϕ 19	265	25.30
F7472 10K100	160	210	175	8 \times ϕ 19	300	37.00
F7472 10K125	180	250	210	8 \times ϕ 23	350	56.60
F7472 10K150	205	280	240	8 \times ϕ 23	400	77.10
F7472 10K200	230	330	290	12 \times ϕ 23	480	116.00
F7472 10K250	290	400	355	12 \times ϕ 25	535	188.00
F7472 10K300	320	445	400	16 \times ϕ 25	610	256.00

Design	Check	Signature	Logo	Supplier
asbsey	Chrit	Figor		PROMET VALVES AUSTRALIA
JAN.01,2013	JAN.01,2013	JAN.01,2013		

PROMET VALVES AUSTRALIA

1A Green Road Woodville West SA 5011 Australia / Tel:+61 8 8268 1777 / Fax:+61 8 8268 1711
 promet@prometvalves.com / www.prometvalves.com / ABN 47 096 425 697