

JISF7378 16K CAST IRON SDNR ANGLE VALVE

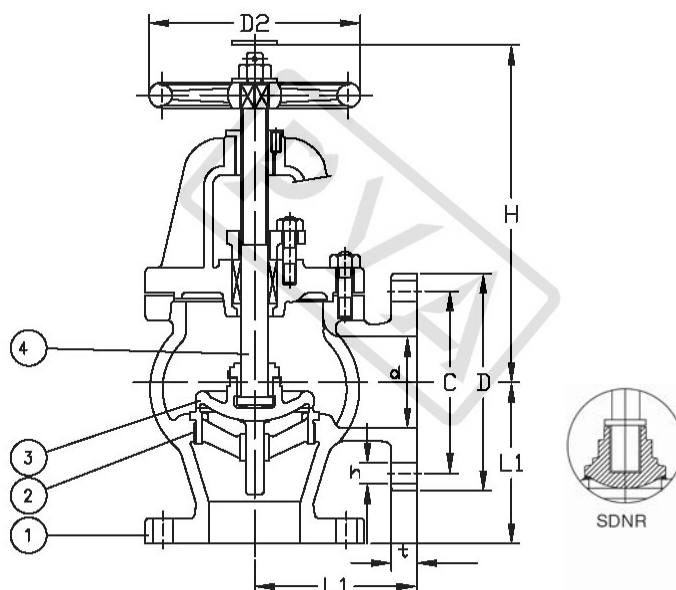

| Pressure Test MPa | | | |
|---------------------|--------|------------|---------|
| Nominal Pressure/PN | 1.6MPa | Shell Test | 3.2 MPa |
| | | Seat Test | 2.4 MPa |

| Main material for fittings | | | |
|----------------------------|-----------|------------------------------|---------------|
| Item | Fittings | Material | Mark |
| 1 | Body | Cast Iron | FC200 |
| 2 | Bonnet | Cast Iron | FC200 |
| 3 | Disc | Stainless Steel/Cast Bronze | SS420/BC6 |
| 4 | Seat | Stainless Steel/Cast Bronze | SS420/BC6 |
| 5 | Stem | Stainless Steel/Forged Brass | SS400/C3771BD |
| 6 | Handwheel | Cast Iron | FC200 |

| Main data for flange connection | | | | | | mm |
|---------------------------------|--------------|-----------------|------------|---------------|--------|--------|
| Model | Face To Face | Flange Diameter | Flange PCD | Flange Hole | Height | Weight |
| | L | D | C | n* ϕ h | H | kgs |
| F7378 16K50 | 120 | 155 | 120 | 8* ϕ 19 | 255 | 18.00 |
| F7378 16K65 | 130 | 175 | 140 | 8* ϕ 19 | 270 | 25.00 |
| F7378 16K80 | 150 | 200 | 160 | 8* ϕ 23 | 295 | 35.70 |
| F7378 16K100 | 170 | 225 | 185 | 8* ϕ 23 | 330 | 49.20 |
| F7378 16K125 | 200 | 270 | 225 | 8* ϕ 25 | 390 | 76.10 |
| F7378 16K150 | 225 | 305 | 260 | 12* ϕ 25 | 435 | 103.00 |
| F7378 16K200 | 250 | 350 | 305 | 12* ϕ 25 | 540 | 155.00 |

| Design | Check | Signature | Logo | Supplier |
|-------------|-------------|-------------|------|-------------------------|
| asbsey | Chrit | Figor | | PROMET VALVES AUSTRALIA |
| JAN.01,2013 | JAN.01,2013 | JAN.01,2013 | | |

PROMET VALVES AUSTRALIA

1A Green Road Woodville West SA 5011 Australia / Tel:+61 8 8268 1777 / Fax:+61 8 8268 1711
 promet@prometvalves.com / www.prometvalves.com / ABN 47 096 425 697