

JISF7318 40K CAST STEEL ANGLE VALVE

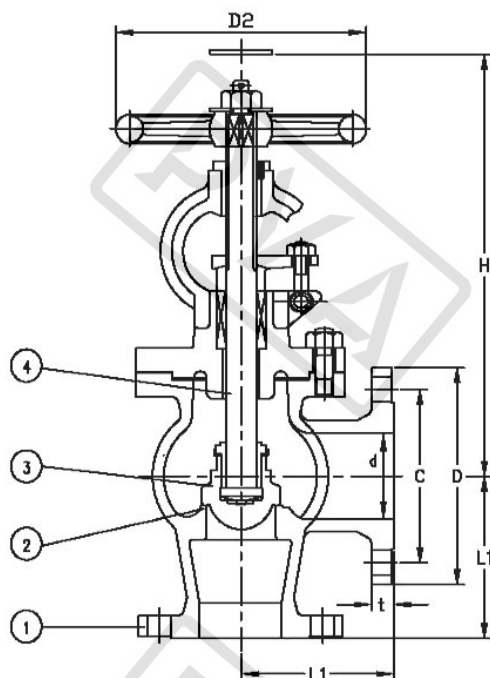

Pressure Test		MPa	
Nominal Pressure/PN	4.0MPa	Shell Test	9.30 MPa
		Seat Test	6.82 MPa

Main material for fittings			
Item	Fittings	Material	Mark
1	Body	Cast Steel	SC230-450
2	Bonnet	Cast Steel	SC230-450
3	Disc	Stainless Steel	SS420J1
4	Seat	Stainless Steel	SS420J1
5	Stem	Stainless Steel	SS400
6	Handwheel	Cast Iron	FC200

Main data for flange connection						mm
Model	Face To Face	Flange Diam.	Flange PCD	Flange Hole	Height	Weight
	L	D	C	n* Φ d	H	kgs
F7318 40K32	114	140	105	4* Φ 19	350	24.90
F7318 40K40	121	160	120	4* Φ 23	370	29.40
F7318 40K50	146	165	130	8* Φ 19	405	40.00
F7318 40K65	165	200	160	8* Φ 23	455	60.30
F7318 40K80	178	210	170	8* Φ 23	500	76.20
F7318 40K100	216	250	205	8* Φ 25	590	135.00
F7318 40K125	254	300	250	8* Φ 27	660	189.00
F7318 40K150	279	355	295	12* Φ 33	740	284.00

Design	Check	Signature	Logo	Supplier
asbsey	Chrit	Figor		PROMET VALVES AUSTRALIA
JAN.01,2013	JAN.01,2013	JAN.01,2013		

PROMET VALVES AUSTRALIA

1A Green Road Woodville West SA 5011 Australia / Tel:+61 8 8268 1777 / Fax:+61 8 8268 1711
 promet@prometvalves.com / www.prometvalves.com / ABN 47 096 425 697