

JISF7314 20K CAST STEEL ANGLE VALVE

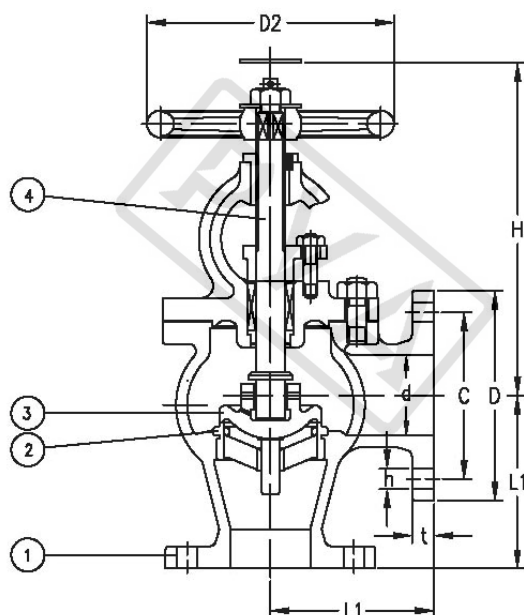

Pressure Test		MPa	
Nominal Pressure/PN	2.0MPa	Shell Test	5.0 MPa
		Seat Test	3.67 MPa

Main material for fittings			
Item	Fittings	Material	Mark
1	Body	Cast Steel	SC230~450
2	Bonnet	Cast Steel	SC230~450
3	Disc	Stainless Steel	SS420
4	Seat	Stainless Steel	SS304
5	Stem	Stainless Steel	SS400
6	Handwheel	Cast Iron	FC200

Main data for flange connection						
						mm
Model	Face To Face	Flange Diam.	Flange PCD	Flange Hole	Height	Weight
	L	D	C	n* \varnothing d	H	kgs
F7314 20K32A	100	135	100	4 \times \varnothing 19	270	13.00
F7314 20K40A	110	140	105	4 \times \varnothing 19	290	15.20
F7314 20K50A	125	155	120	8 \times \varnothing 19	305	20.00
F7314 20K65A	135	175	140	8 \times \varnothing 19	345	26.90
F7314 20K80A	150	200	160	8 \times \varnothing 23	385	38.90
F7314 20K100A	170	225	182	8 \times \varnothing 23	440	54.40
F7314 20K125A	200	270	225	8 \times \varnothing 25	500	80.70
F7314 20K150A	225	305	260	12 \times \varnothing 25	550	112.30
F7314 20K200A	280	350	305	12 \times \varnothing 25	630	183.00
F7314 20K250A	310	430	380	12 \times \varnothing 27	725	285.90

Design	Check	Signature	Logo	Supplier
asbsey	Chrit	Figor		PROMET VALVES AUSTRALIA
JAN.01,2013	JAN.01,2013	JAN.01,2013		

PROMET VALVES AUSTRALIA

1A Green Road Woodville West SA 5011 Australia / Tel:+61 8 8268 1777 / Fax:+61 8 8268 1711
 promet@prometvalves.com / www.prometvalves.com / ABN 47 096 425 697