

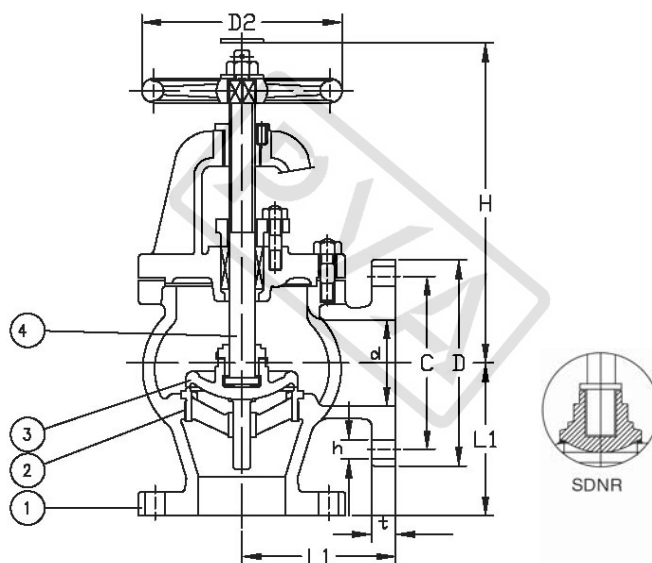

JISF7312C 5K CAST STEEL SDNR ANGLE VALVE



Pressure Test		MPa	
Nominal Pressure/PN	0.5MPa	Shell Test	1.03 MPa
		Seat Test	0.76 MPa

Main material for fittings			
Item	Fittings	Material	Mark
1	Body	Cast Steel	SC230~450
2	Bonnet	Cast Steel	SC230~450
3	Disc	Stainless Steel/Cast Bronze	SS420/BC6
4	Seat	Stainless Steel/Cast Bronze	SS420/BC6
5	Stem	Stainless Steel/Forged Brass	SS400/C3771BD
6	Handwheel	Cast Iron	FC200

Main data for flange connection						
Model	Face To Face	Flange Diam.	Flange PCD	Flange Hole	Height	Weight
	L	D	C	n*φd	H	kgs
F7312C 5K50	100	130	105	4*φ15	240	12.90
F7312C 5K65	115	155	130	4*φ15	255	18.20
F7312C 5K80	130	180	145	4*φ19	265	23.30
F7312C 5K100	150	200	165	8*φ19	310	33.50
F7312C 5K125	170	235	200	8*φ19	330	46.50
F7312C 5K150	190	265	230	8*φ19	380	64.00
F7312C 5K200	220	320	280	8*φ23	450	104.00
F7312C 5K250	275	385	345	12*φ23	540	178.00
F7312C 5K300	310	430	390	12*φ23	610	275.00
F7312C 5K350	360	480	435	12*φ25	690	
F7312C 5K400	395	540	495	16*φ25	770	

Design	Check	Signature	Logo	Supplier
asbsey	Chrit	Figor		PROMET VALVES AUSTRALIA
JAN.01,2013	JAN.01,2013	JAN.01,2013		

PROMET VALVES AUSTRALIA

1A Green Road Woodville West SA 5011 Australia / Tel:+61 8 8268 1777 / Fax:+61 8 8268 1711
 promet@prometvalves.com / www.prometvalves.com / ABN 47 096 425 697