

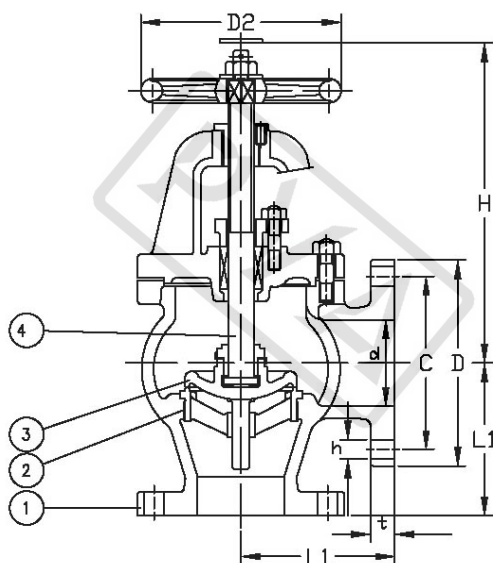

JISF7312 5K CAST STEEL ANGLE VALVE



Pressure Test		MPa	
Nominal Pressure/PN	0.5MPa	Shell Test	1.03 MPa
		Seat Test	0.76 MPa

Main material for fittings			
Item	Fittings	Material	Mark
1	Body	Cast Steel	SC230~450
2	Bonnet	Cast Steel	SC230~450
3	Disc	Stainless Steel/Cast Bronze	SS420/BC6
4	Seat	Stainless Steel/Cast Bronze	SS420/BC6
5	Stem	Stainless Steel/Forged Brass	SS400/C3771BD
6	Handwheel	Cast Iron	FC200

Main data for flange connection						
Model	Face To Face	Flange Diam.	Flange PCD	Flange Hole	Height	Weight
	L	D	C	n* \varnothing d	H	kgs
F7312 5K50	100	130	105	4 \times \varnothing 15	240	12.90
F7312 5K65	115	155	130	4 \times \varnothing 15	255	18.20
F7312 5K80	130	180	145	4 \times \varnothing 19	265	23.40
F7312 5K100	150	200	165	8 \times \varnothing 19	310	33.70
F7312 5K125	170	235	200	8 \times \varnothing 19	330	46.20
F7312 5K150	190	265	230	8 \times \varnothing 19	380	63.40
F7312 5K200	220	320	280	8 \times \varnothing 23	450	105.00
F7312 5K250	275	385	345	12 \times \varnothing 23	540	178.00
F7312 5K300	310	430	390	12 \times \varnothing 23	610	275.00
F7312 5K350	360	480	435	12 \times \varnothing 25	690	327.00
F7312 5K400	395	540	495	16 \times \varnothing 25	770	459.00

Design	Check	Signature	Logo	Supplier
asbsey	Chrit	Figor		PROMET VALVES AUSTRALIA
JAN.01,2013	JAN.01,2013	JAN.01,2013		

PROMET VALVES AUSTRALIA

1A Green Road Woodville West SA 5011 Australia / Tel:+61 8 8268 1777 / Fax:+61 8 8268 1711
 promet@prometvalves.com / www.prometvalves.com / ABN 47 096 425 697