

JISF7310 16K CAST IRON ANGLE VALVE

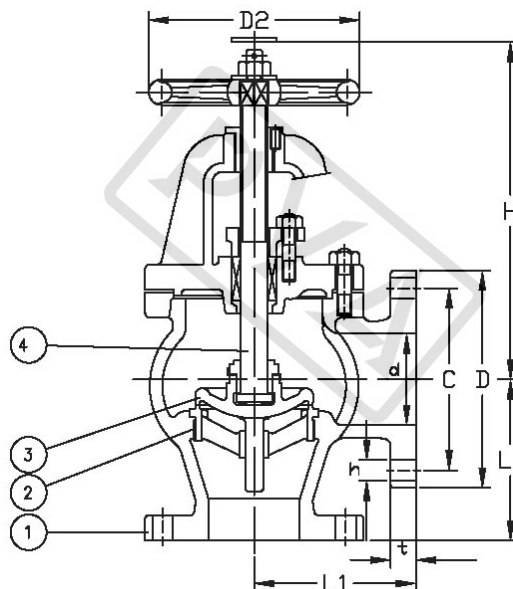

Pressure Test MPa			
Nominal Pressure/PN	1.6MPa	Shell Test	3.2 MPa
		Seat Test	2.4 MPa

Main material for fittings			
Item	Fittings	Material	Mark
1	Body	Cast Iron	FC200
2	Bonnet	Cast Iron	FC200
3	Disc	Stainless Steel/Cast Bronze	SS420/BC6
4	Seat	Stainless Steel/Cast Bronze	SS420/BC6
5	Stem	Stainless Steel/Forged Brass	SS400/C3771BD
6	Handwheel	Cast Iron	FC200

Main data for flange connection						
Model	Face To Face	Flange Diameter	Flange PCD	Flange Hole	Height	Weight
	L	D	C	n* ϕ h	H	kgs
F7310 16K50	120	155	120	8 \times ϕ 19	255	18.00
F7310 16K65	130	175	140	8 \times ϕ 19	270	25.00
F7310 16K80	150	200	160	8 \times ϕ 23	295	35.70
F7310 16K100	170	225	185	8 \times ϕ 23	330	49.20
F7310 16K125	200	270	225	8 \times ϕ 25	390	76.10
F7310 16K150	225	305	260	12 \times ϕ 25	435	103.00
F7310 16K200	250	350	305	12 \times ϕ 25	540	155.00

Design	Check	Signature	Logo	Supplier
asbsey	Chrit	Figor		PROMET VALVES AUSTRALIA
JAN.01,2013	JAN.01,2013	JAN.01,2013		

PROMET VALVES AUSTRALIA

1A Green Road Woodville West SA 5011 Australia / Tel:+61 8 8268 1777 / Fax:+61 8 8268 1711
 promet@prometvalves.com / www.prometvalves.com / ABN 47 096 425 697