

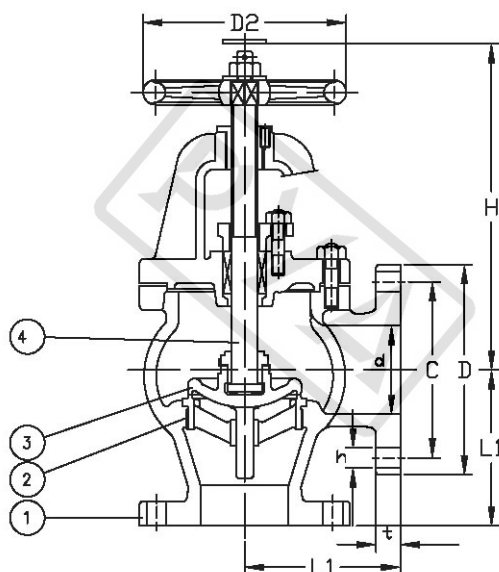

JISF7308 10K CAST IRON ANGLE VALVE



Pressure Test		MPa	
Nominal Pressure/PN	1.0MPa	Shell Test	2.1 MPa
		Seat Test	1.54 MPa

Main material for fittings			
Item	Fittings	Material	Mark
1	Body	Cast Iron	FC200
2	Bonnet	Cast Iron	FC200
3	Disc	Stainless Steel/Cast Bronze	SS420/BC6
4	Seat	Stainless Steel/Cast Bronze	SS420/BC6
5	Stem	Stainless Steel/Forged Brass	SS400/C3771BD
6	Handwheel	Cast Iron	FC200

Main data for flange connection						mm
Model	Face To Face	Flange Diam.	Flange PCD	Flange Hole	Height	Weight
	L1	D	C	n*Φd	H	kgs
F7308 10K50	120	155	120	4×Φ19	255	18.20
F7308 10K65	130	175	140	4×Φ19	270	25.40
F7308 10K80	140	185	150	8×Φ19	275	27.40
F7308 10K100	160	210	175	8×Φ19	315	40.60
F7308 10K125	180	250	210	8×Φ23	360	69.90
F7308 10K150	205	280	240	8×Φ23	405	81.00
F7308 10K200	230	330	290	12×Φ23	475	125.00
F7308 10K250	290	400	355	12×Φ25	570	211.00
F7308 10K300	320	445	400	16×Φ25	645	293.00
F7308 10K350	360	490	445	16×Φ25	710	386.00
F7308 10K400	420	560	510	16×Φ27	790	544.00

Design	Check	Signature	Logo	Supplier
asbsey	Chrit	Figor		PROMET VALVES AUSTRALIA
JAN.01,2013	JAN.01,2013	JAN.01,2013		

PROMET VALVES AUSTRALIA

1A Green Road Woodville West SA 5011 Australia / Tel:+61 8 8268 1777 / Fax:+61 8 8268 1711
 promet@prometvalves.com / www.prometvalves.com / ABN 47 096 425 697