

Flanschen-Rückschlagventil, absperrbar, GS-C25/Bronze mit Bügeldeckel und Feder

Screw-down stop and check valve, flanged, cast steel/bronze with bolted bonnet and spring

Nenndruck / Nominal pressure PN40

Art.Nr. 20.02.21 Form A Durchgangsform / straight type

Art.Nr. 20.02.22 Form B Eckform / angle type

Verwendungsbereich:

Geeignet für Wasser, Dampf, Öl und andere neutrale, nicht aggressive Flüssigkeiten und Gase.

Verwendbar für Temperaturen von -10°C bis 400°C

Zulässige Betriebstemperaturen und -drücke:

bis 120°C	max. 40 bar
200°C	35 bar
250°C	32 bar
300°C	28 bar
350°C	24 bar
400°C	21 bar

Zulässige Differenzdrücke Δp:

DN 125	33 bar
150	21 bar
200	14 bar

Sonderausführungen:

- ◇ Gehäuse aus Niro, EN-GJL-250, EN-GJS-400-18-LT
- ◇ Innenteile aus Niro
- ◇ Flansche PN10, PN16
- ◇ Flansche nach ANSI, BS usw. auf Anfrage
- ◇ Anzeigevorrichtung

Application:

Suitable for water, steam, oil and other neutral non aggressive liquids and gases.

Application for temperatures from -10°C up to 400°C

Admissible temperatures and pressures:

up to 120°C	max. 40 bar
200°C	35 bar
250°C	32 bar
300°C	28 bar
350°C	24 bar
400°C	21 bar

Admissible differential pressures Δp:

DN 125	33 bar
150	21 bar
200	14 bar

Special design:

- ◇ Body material stainless steel, EN-GJL-250, EN-GJS-400-18-LT
- ◇ Innerparts material stainless steel
- ◇ Flanges PN10, PN16
- ◇ Flanges acc. ANSI, BS etc. on request
- ◇ Indicator

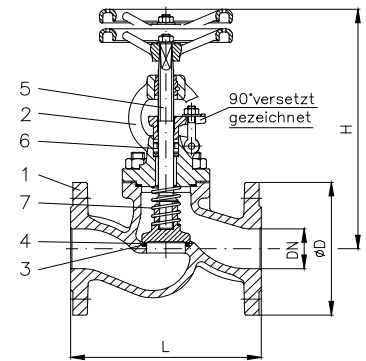

Art.Nr. 20.02.21

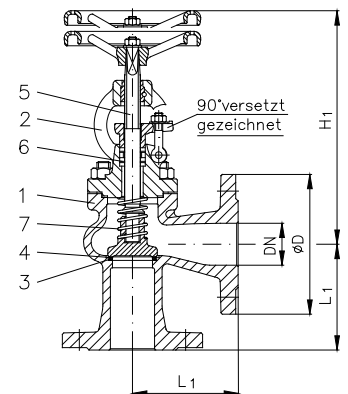

Art.Nr. 20.02.22

Teil Part	Bezeichnung Name	Werkstoff nach DIN Material acc. to DIN		Werkstoff nach BS Material acc. to BS	
1	Gehäuse Form A / body form A	DN 15 - 25	P250 GH	---	
		DN 32 - 250	GP240 GH	B.S.1504:161:1964 Gr.B	
1	Gehäuse Form B / body form B	GP240 GH		B.S.1504:161:1964 Gr.B	
2	Bügeldeckel / bonnet	DN 15 - 50	P250 GH	---	
		DN 65 - 250	GP240 GH	B.S.1504:161:1964 Gr.B	
3	Gehäusesitzring / body seat ring	CuSn 6		B.S.:2874:1962 PB 103	
4	Kegelsitzring / disc seat ring	DN 15 - 50	CuAl10 Fe	---	
		DN 65 - 250	CuSn 6	B.S.:2874:1962 PB 103	
5	Spindel / stem	CuZn38 Pb		---	
6	Stopfbuchspackung / gland packing	Graphit		---	
7	Feder / spring	CuSn 6		B.S.:2874:1962 PB 103	

Flansch / flange									Form A	Form B
DN	Ø D	Ø k x n x Ø d1	L	L1	H	H1	Hub		≈ kg	≈ kg
15	95	65 x 4 x 14	130	90	197	182	12		4,6	4,1
20	105	75 x 4 x 14	150	95	197	182	12		5,3	4,7
25	115	85 x 4 x 14	160	100	197	182	12		6,0	4,9
32	140	100 x 4 x 18	180	105	270	250	10		11,0	10,6
40	150	110 x 4 x 18	200	115	282	262	12		12,3	13,6
50	165	125 x 4 x 18	230	125	296	281	16		16,0	16,0
65	185	145 x 8 x 18	290	145	336	306	16		27,5	28,0
80	200	160 x 8 x 18	310	155	390	340	20		36,0	37,0
100	235	190 x 8 x 22	350	175	427	375	25		52,0	48,0
125	270	220 x 8 x 26	400	200	476	430	40		60,0	59,2
150	300	250 x 8 x 26	480	225	541	495	45		86,0	75,5
200	375	320 x 12 x 30	600	275	636	575	60		175,0	152,5
250	450	385 x 12 x 33	730	-	730	-	65		326,0	-