

Flanschen-Rückschlagventil, absperrbar DIN 86261, Rg 5/CuAl10 Ni mit Bügeldeckel

Screw-down stop and check valve, flanged DIN 86261, gunmetal/CuAl10 Ni with bolted bonnet

Nenndruck / Nominal pressure

DN 15 – DN 125 **PN16** DN 150 – DN 200 **PN10** DN 250 – DN 300 **PN 6** DN 350 – DN 500 **PN 4**

Art.Nr. 20.02.01 Form A Durchgangsform / straight type

Art.Nr. 20.02.02 Form B Eckform / angle type

Verwendungsbereich:

Geeignet für kaltes und heißes Wasser, Satteldampf, Öl und andere neutrale, nicht aggressive Medien.

Bei Verwendung für dünnflüssige Medien oder Luft ist ein Sondereinschliff der Dichtflächen erforderlich.

(Bitte Art, Druck und Temperatur des Mediums angeben.)

Verwendbar für Temperaturen bis 225°C (Dampf bis 180°C)

Zulässige Betriebstemperaturen und -drücke:

max. Druck	bis 120°C	über 120°C
DN 15 - 125	16 bar	10 bar
DN 150 - 200	10 bar	6 bar
DN 250 - 300	6 bar	4 bar
DN 350 - 500	4 bar	2 bar

Sonderausführungen:

- ◇ Kegel mit auswechselbarer Dichtung (PTFE, NBR usw.)
- ◇ Spindel aus CuSn 6, CuZn35 Ni usw.
- ◇ Ventile aus G-CuSn10 Zn, CuSn10-C usw.
- ◇ Ventile Ausführung: Rg 03 und Gbz 03 mit Sitzring aus CuAl10 Ni usw.
- ◇ Ventile PN 6, 25, 40, ANSI usw.
- ◇ Ventile mit Schließfeder

Application:

Suitable for cold and hot water, saturated steam, oil and other neutral non aggressive liquids.

For the application for high fluid liquids or air a special sealing surface is necessary.

(Please inform us about type of the liquid, pressure and temperature.)

Application for temperatures up to 225°C (steam up to 180°C)

Admissible temperatures and pressures:

max. pressure	up to 120°C	over 120°C
DN 15 - 125	16 bar	10 bar
DN 150 - 200	10 bar	6 bar
DN 250 - 300	6 bar	4 bar
DN 350 - 500	4 bar	2 bar

Special design:

- ◇ Disc with exchangeable sealing (PTFE, NBR, etc.)
- ◇ Stem material CuSn 6, CuZn35 Ni etc.
- ◇ Valves mat. G-CuSn10 Zn, CuSn10-C etc.
- ◇ Valves design acc. Rg 03 and Gbz 03 with seat ring in CuAl10 Ni etc.
- ◇ Valves PN 6, 25, 40, ANSI etc.
- ◇ Valves with spring

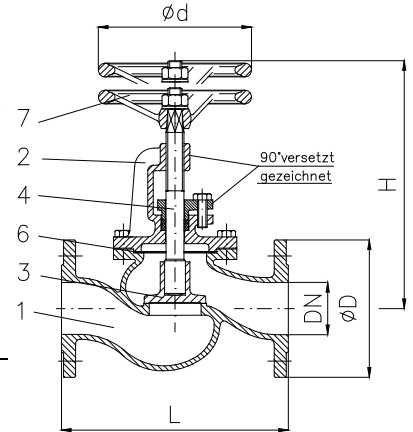

Art.Nr. 20.02.01

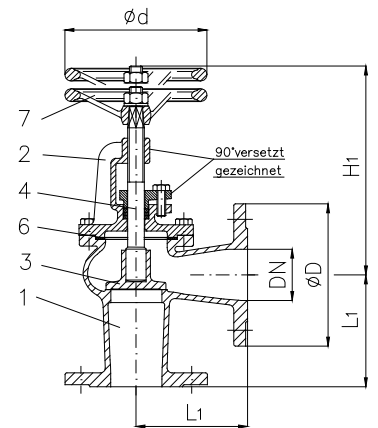

Art.Nr. 20.02.02

Teil Part	Bezeichnung Name	Werkstoff nach DIN Material acc. to DIN	Werkstoff nach BS Material acc. to BS
1	Gehäuse / body	CuSn5Zn5Pb5-C	B.S.1400:1961 LG 2-C
2	Bügeldeckel / bonnet	CuSn5Zn5Pb5-C	B.S.1400:1961 LG 2-C
3	Kegel / disc	bis DN 32 CuZn35 Ni ab DN 40 CuSn5Zn5Pb5-C	B.S.2874:1962 CZ 114 B.S.1400:1961 LG 2-C
4	Spindel / stem	CuAl10 Ni	B.S.2032:1963 CA 103
6	Deckeldichtung / bonnet sealing	FA1 / asbestfrei	---
7	Handrad / handwheel	EN-GJL-250, schwarz lackiert	B.S.1452:1990 Gr.150/180

Flansch / flange								
DN	Ø D	Ø k x n x Ø d1	L	L1	H	H1	Ø d	Hub
15	95	65 x 4 x 14	130	90	180	160	100	6
20	105	75 x 4 x 14	150	95	200	170	100	7
25	115	85 x 4 x 14	160	100	310	170	100	8
32	140	100 x 4 x 18	180	105	220	190	125	10
40	150	110 x 4 x 18	200	115	250	210	160	12
50	165	125 x 4 x 18	230	125	250	220	160	15
65	185	145 x 4 x 18	290	145	315	260	200	19
80	200	160 x 8 x 18	310	155	335	280	200	24
100	220	180 x 8 x 18	350	175	360	300	250	27
125	250	210 x 8 x 18	400	200	405	340	250	32
150	285	240 x 8 x 22	480	225	460	360	315	40
175	315	270 x 8 x 22	550	250	520	380	315	48
200	340	295 x 8 x 22	600	275	550	440	400	56
250	395	350 x 12 x 22	730	325	670	550	400	65
300	445	400 x 12 x 22	850	375	750	620	400	80
350	505	460 x 16 x 22	980	425	850	720	500	90
400	565	515 x 16 x 26	1100	475	910	750	500	105
450	615	565 x 20 x 26	1200	500	970	925	500	115
500	670	620 x 20 x 26	1250	590	1095	950	500	130

Form A		Form B	
kv	≈ kg	kv	≈ kg
6	5,0	7	3,8
8	5,5	10	4,0
11	6,0	15	5,0
17	8,0	27	7,0
29	10,0	39	9,0
47	12,0	71	11,0
78	17,0	108	16,0
114	23,0	150	20,0
192	30,0	235	25,0
234	50,0	360	40,0
410	65,0	510	50,0
560	85,0	696	75,0
725	110,0	905	95,0
1145	165,0	1430	155,0
1635	295,0	2040	225,0
2220	480,0	2775	360,0
3180	510,0	3975	400,0
3659	1150,0	4600	650,0
4530	1300,0	5660	800,0