

Flanschen-Absperrventil DIN 86260, Rg 10/CuSn 6 mit Bügeldeckel und Regulierkegel

Stop valve, flanged DIN 86260, Rg 10/CuSn 6 with bolted bonnet and regulating disc

Nenndruck / Nominal pressure

DN 15 – DN 125 **PN16** DN 150 – DN 200 **PN10** DN 250 – DN 300 **PN 6** DN 350 – DN 500 **PN 4**

Art.Nr. 20.01.51 Form A Durchgangsform / straight type

Art.Nr. 20.01.52 Form B Eckform / angle type

Verwendungsbereich:

Geeignet für kaltes und heißes Wasser, Satteldampf, Öl und andere neutrale, nicht aggressive Medien.

Bei Verwendung für dünnflüssige Medien oder Luft ist ein Sondereinschliff der Dichtflächen erforderlich.

(Bitte Art, Druck und Temperatur des Mediums angeben.)

Verwendbar für Temperaturen bis 225°C (Dampf bis 180°C)

Zulässige Betriebstemperaturen und -drücke:

max. Druck	bis 120°C	über 120°C
DN 15 - 125	16 bar	10 bar
DN 150 - 200	10 bar	6 bar
DN 250 - 300	6 bar	4 bar
DN 350 - 500	4 bar	2 bar

Sonderausführungen:

- ◇ Kegel mit auswechselbarer Dichtung (PTFE, NBR usw.)
- ◇ Spindel aus CuZn35 Ni, CuAl10 Ni usw.
- ◇ Ventile aus CuSn5Zn5Pb5-C, CuSn10-C usw.
- ◇ Ventile Ausführung: Rg 03 und Gbz 03 mit Sitzring aus CuAl10 Ni usw.
- ◇ Ventile PN 6, 25, 40, ANSI usw.

Application:

Suitable for cold and hot water, saturated steam, oil and other neutral non aggressive liquids.

For the application for high fluid liquids or air a special sealing surface is necessary.

(Please inform us about type of the liquid, pressure and temperature.)

Application for temperatures up to 225°C (steam up to 180°C)

Admissible temperatures and pressures:

max. pressure	up to 120°C	over 120°C
DN 15 - 125	16 bar	10 bar
DN 150 - 200	10 bar	6 bar
DN 250 - 300	6 bar	4 bar
DN 350 - 500	4 bar	2 bar

Special design:

- ◇ Disc with exchangeable sealing (PTFE, NBR etc.)
- ◇ Stem material CuZn35 Ni, CuAl10 Ni etc.
- ◇ Valves material CuSn5Zn5Pb5-C, CuSn10-C etc.
- ◇ Valves design acc. Rg 03 and Gbz 03 with seat ring in CuAl10 Ni etc.
- ◇ Valves PN 6, 25, 40, ANSI etc.

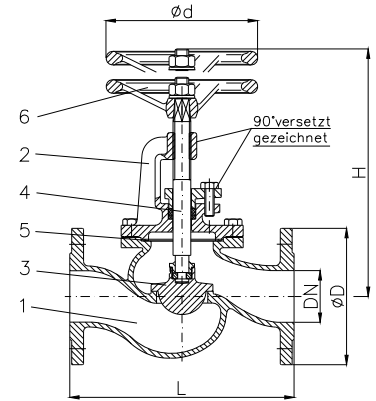

Art.Nr. 20.01.51

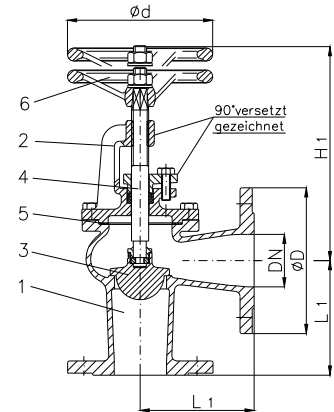

Art.Nr. 20.01.52

Teil Part	Bezeichnung Name	Werkstoff nach DIN Material acc. to DIN	Werkstoff nach BS Material acc. to BS
1	Gehäuse / body	G-CuSn10 Zn	B.S.1400:1961 G 1-C
2	Bügeldeckel / bonnet	G-CuSn10 Zn	B.S.1400:1961 G 1-C
3	Kegel / disc	G-CuSn10 Zn	B.S.1400:1961 G 1-C
4	Spindel / stem	CuSn 6	B.S.2874:1962 PB 103
5	Deckeldichtung / bonnet sealing	FA1 / asbestfrei	---
6	Handrad / handwheel	EN-GJL-250, schwarz lackiert	B.S.1452:1990 Gr.150/180

Flansch / flange								
DN	Ø D	Ø k x n x Ø d1	L	L1	H	H1	Ø d	Hub
15	95	65 x 4 x 14	130	90	180	160	100	6
20	105	75 x 4 x 14	150	95	200	170	100	7
25	115	85 x 4 x 14	160	100	210	170	100	8
32	140	100 x 4 x 18	180	105	220	190	125	10
40	150	110 x 4 x 18	200	115	250	210	160	12
50	165	125 x 4 x 18	230	125	250	220	160	15
65	185	145 x 4 x 18	290	145	315	260	200	19
80	200	160 x 8 x 18	310	155	335	280	200	24
100	220	180 x 8 x 18	350	175	375	300	250	28
125	250	210 x 8 x 18	400	200	420	340	250	36
150	285	240 x 8 x 22	480	225	460	360	315	40
175	315	270 x 8 x 22	550	250	520	380	315	48
200	340	295 x 8 x 22	600	275	550	440	400	56
250	395	350 x 12 x 22	730	325	670	550	400	65
300	445	400 x 12 x 22	850	375	750	620	400	80
350	505	460 x 16 x 22	980	425	850	720	500	90
400	565	515 x 16 x 26	1100	475	910	750	500	105
450	615	565 x 20 x 26	1200	500	970	925	500	115
500	670	620 x 20 x 26	1250	590	1095	950	500	130

Form A		Form B	
kv	≈ kg	kv	≈ kg
6	5,0	7	3,8
8	5,5	9	4,0
11	6,0	14	5,0
17	8,0	23	7,0
27	10,0	36	9,0
42	12,0	56	11,0
60	17,0	94	16,0
114	23,0	143	20,0
192	30,0	224	25,0
232	50,0	349	40,0
404	65,0	503	50,0
555	85,0	685	75,0
723	110,0	894	95,0
1145	165,0	1398	155,0
1635	295,0	2012	225,0
2220	480,0	2739	360,0
3180	510,0	3578	400,0
3659	1150,0	4528	650,0
4530	1300,0	5590	800,0