

Flanschen-Absperrventil DIN 86260, Rg 5/SoMs 59 mit Bügeldeckel

Stop valve, flanged DIN 86260, gunmetal/SoMs 59 with bolted bonnet

Nenndruck / Nominal pressure

DN 15 – DN 125 **PN16** DN 150 – DN 200 **PN10** DN 250 – DN 300 **PN 6** DN 350 – DN 500 **PN 4**

Art.Nr. 20.01.01 Form A Durchgangsform / straight type

Art.Nr. 20.01.02 Form B Eckform / angle type

Verwendungsbereich:

Geeignet für kaltes und heißes Wasser, Satt-
dampf, Öl und andere neutrale, nicht aggres-
sive Medien.

Bei Verwendung für dünnflüssige Medien
oder Luft ist ein Sondereinschliff der Dicht-
flächen erforderlich.

(Bitte Art, Druck und Temperatur des
Mediums angeben.)

Verwendbar für Temperaturen bis 225°C
(Dampf bis 180°C)

Zulässige Betriebstemperaturen und -drücke:

max. Druck	bis 120°C	über 120°C
DN 15 - 125	16 bar	10 bar
DN 150 - 200	10 bar	6 bar
DN 250 - 300	6 bar	4 bar
DN 350 - 500	4 bar	2 bar

Sonderausführungen:

- ◇ Kegel mit auswechselbarer Dichtung
(PTFE, NBR usw.)
- ◇ Regulierkegel
- ◇ Spindel aus CuSn 6, CuAl10 Ni, Niro
usw.
- ◇ Ventile aus G-CuSn10 Zn, CuSn10-C usw.
- ◇ Ventile Ausführung: Rg 03 und Gbz 03 mit
Sitzring aus CuAl10 Ni usw.
- ◇ Ventile PN 6, 25, 40, ANSI usw.

Application:

Suitable for cold and hot water, saturated
steam, oil and other neutral non aggressive
liquids.

For the application for high fluid liquids or air
a special sealing surface is necessary.

(Please inform us about type of the liquid,
pressure and temperature.)

Application for temperatures up to 225°C
(steam up to 180°C)

Admissible temperatures and pressures:

max. pressure	up to 120°C	over 120°C
DN 15 - 125	16 bar	10 bar
DN 150 - 200	10 bar	6 bar
DN 250 - 300	6 bar	4 bar
DN 350 - 500	4 bar	2 bar

Special design:

- ◇ Disc with exchangeable sealing
(PTFE, NBR etc.)
- ◇ Regulate disc
- ◇ Stem material CuSn 6, CuAl10 Ni,
stainless steel etc.
- ◇ Valves mat. G-CuSn10 Zn, CuSn10-C etc.
- ◇ Valves design acc. Rg 03 and Gbz 03 with
seat ring in CuAl10 Ni etc.
- ◇ Valves PN 6, 25, 40, ANSI etc.

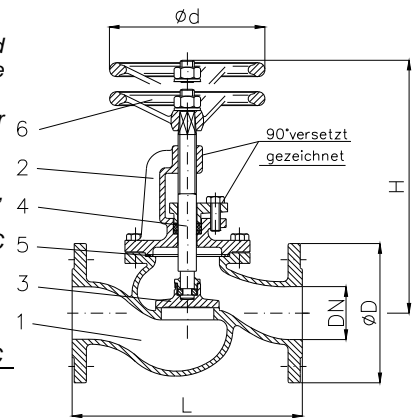

Art.Nr. 20.01.01

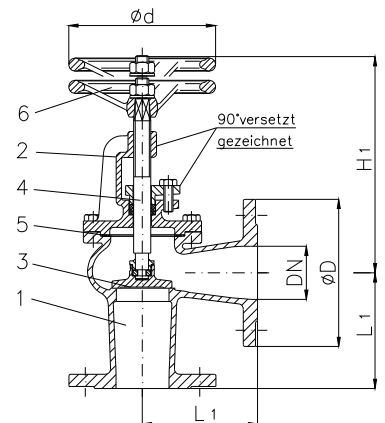

Art.Nr. 20.01.02

Teil Part	Bezeichnung Name	Werkstoff nach DIN Material acc. to DIN	Werkstoff nach BS Material acc. to BS
1	Gehäuse / body	CuSn5Zn5Pb5-C	BS 1400:1961 LG 2-C
2	Bügeldeckel / bonnet	CuSn5Zn5Pb5-C	BS 1400:1961 LG 2-C
3	Kegel / disc	bis DN 32 CuZn35 Ni ab DN 40 CuSn5Zn5Pb5-C	BS 2874:1962 CZ 114 BS 1400:1961 LG 2-C
4	Spindel / stem	CuZn35 Ni	BS 2874:1962 CZ 114
5	Deckeldichtung / bonnet sealing	FA1 / asbestfrei	---
6	Handrad / handwheel	EN-GJL-250, schwarz lackiert	BS 1452:1990 Gr.150/180

Flansch / flange									Form A		Form B	
DN	Ø D	Ø k x n x Ø d1	L	L1	H	H1	Ø d	Hub	kv	≈ kg	kv	≈ kg
15	95	65 x 4 x 14	130	90	180	160	100	6	6	5,0	7	3,8
20	105	75 x 4 x 14	150	95	200	170	100	7	8	5,5	10	4,0
25	115	85 x 4 x 14	160	100	210	170	100	8	11	6,0	15	5,0
32	140	100 x 4 x 18	180	105	220	190	125	10	17	8,0	27	7,0
40	150	110 x 4 x 18	200	115	250	210	160	12	29	10,0	39	9,0
50	165	125 x 4 x 18	230	125	250	220	160	15	47	12,0	71	11,0
65	185	145 x 4 x 18	290	145	315	260	200	19	78	17,0	108	16,0
80	200	160 x 8 x 18	310	155	335	280	200	24	114	23,0	150	20,0
100	220	180 x 8 x 18	350	175	375	300	250	28	192	30,0	235	25,0
125	250	210 x 8 x 18	400	200	420	340	250	36	234	50,0	360	40,0
150	285	240 x 8 x 22	480	225	460	360	315	40	410	65,0	510	50,0
200	340	295 x 8 x 22	600	275	550	440	400	56	725	110,0	905	95,0
250	395	350 x 12 x 22	730	325	670	550	400	65	1145	165,0	1430	155,0
300	445	400 x 12 x 22	850	375	750	620	400	80	1635	295,0	2040	225,0
350	505	460 x 16 x 22	980	425	850	720	500	90	2220	480,0	2775	360,0
400	565	515 x 16 x 26	1100	475	910	750	500	105	3180	510,0	3975	400,0
450	615	565 x 20 x 26	1200	500	970	925	500	115	3659	1150,0	4600	650,0
500	670	620 x 20 x 26	1250	590	1095	950	500	130	4530	1300,0	5660	800,0