

Flanschen-Absperrventil, GS-C25/Niro mit Bügeldeckel

**Stop valve, flanged, cast steel/stainless steel
with bolted bonnet**

Nenndruck / Nominal pressure PN40

Art.Nr. 20.01.01 Form A Durchgangsform / *straight type*

Art.Nr. 20.01.02 Form B Eckform / *angle type*

Verwendungsbereich:

Geeignet für Frischwasser, Öl, und andere neutrale, nicht aggressive Flüssigkeiten und Gase.

Verwendbar für Temperaturen von -10°C bis 400°C

Zulässige Betriebstemperaturen und -drücke:

bis 120°C	max. 40 bar
200°C	35 bar
250°C	32 bar
300°C	28 bar
350°C	24 bar
400°C	21 bar

Maximaler Differenzdruck:

DN 125	25 bar
DN 150	21 bar
DN 200	14 bar
DN 250	9 bar
DN 300	6 bar

Sonderausführungen:

- ◇ Gehäuse und Deckel aus EN-GJL-250, EN-GJS-400-18-LT
- ◇ Gehäuse aus Niro
- ◇ Innenteile aus Bronze
- ◇ Flansche PN10, PN16
- ◇ Flansche nach ANSI, BS usw. auf Anfrage
- ◇ Entlastungskegel für höhere Differenzdrücke
- ◇ Kegel mit Kegelverschraubung
- ◇ Regulierkegel
- ◇ Anzeigevorrichtung

Application:

Suitable for fresh water, oil, and other neutral non aggressive liquids and gases.

Application for temperatures from -10°C up to 400°C

Admissible temperatures and pressures:

up to 120°C	max. 40 bar
200°C	35 bar
250°C	32 bar
300°C	28 bar
350°C	24 bar
400°C	21 bar

Maximal pressure difference:

DN 125	25 bar
DN 150	21 bar
DN 200	14 bar
DN 250	9 bar
DN 300	6 bar

Special design:

- ◇ body and bonnet material EN-GJL-250, EN-GJS-400-18-LT
- ◇ body material stainless steel
- ◇ innerparts material bronze
- ◇ flanges PN10, PN16
- ◇ flanges acc. ANSI, BS etc. on request
- ◇ balanced disc for higher pressure difference
- ◇ disc with screwed locking
- ◇ regulate disc
- ◇ indicator

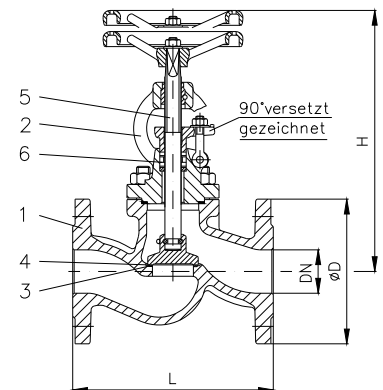

Art.Nr. 20.01.01

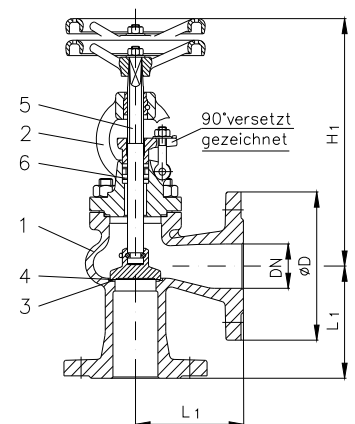

Art.Nr. 20.01.02

Teil Part	Bezeichnung Name	Werkstoff nach DIN Material acc. to DIN	Werkstoff nach BS Material acc. to BS
1	Gehäuse Form A / <i>body form A</i>	DN 15 - 25 P250 GH DN 32 - 250 GP240 GH	--- BS 1504:161:1964 Gr.B
1	Gehäuse Form B / <i>body form B</i>	GP240 GH	BS 1504:161:1964 Gr.B
2	Bügeldeckel / <i>bonnet</i>	DN 15 - 50 P250 GH	---
3	Gehäusesitzring / <i>body seat ring</i>	DN 65 - 250 GP240 GH DN 15 - 25 Cr 17	BS 1504:161:1964 Gr.B ---
4	Kegelsitzring / <i>disc seat ring</i>	DN 32 - 250 CrNi 18.8	---
5	Spindel / <i>stem</i>	DN 15 - 80 Cr 13	---
6	Stopfbuchspackung / <i>gland packing</i>	DN 100 - 250 CrNi 18.8 Graphit	---

Flansch / <i>flange</i>									Form A	Form B
DN	Ø D	Ø k x n x Ø d1	L	L1	H	H1	Hub		≈ kg	≈ kg
15	95	65 x 4 x 14	130	90	180	189	14		4,6	4,3
20	105	75 x 4 x 14	150	95	184	189	14		5,3	4,8
25	115	85 x 4 x 14	160	100	188	189	14		6,0	5,0
32	140	100 x 4 x 18	180	105	273	253	13		11,0	10,6
40	150	110 x 4 x 18	200	115	292	277	22		12,3	12,0
50	165	125 x 4 x 18	230	125	300	280	25		16,0	15,5
65	185	145 x 8 x 18	290	145	345	315	25		28,0	28,0
80	200	160 x 8 x 18	310	155	397	347	27		37,9	37,4
100	235	190 x 8 x 22	350	175	442	397	37		50,0	50,0
125	270	220 x 8 x 26	400	200	494	448	58		63,0	61,0
150	300	250 x 8 x 26	480	225	566	510	70		86,0	75,0
200	375	320 x 12 x 30	600	275	668	607	92		175,0	151,0
250	450	385 x 12 x 33	730	325	775	710	110		326,0	237,0
300	515	450 x 16 x 33	850	375	910	850	125		375,0	388,0