

Flanschen-Absperrventil, GG 25/Niro mit Bügeldeckel

**Stop valve, flanged, cast iron/stainless steel
with bolted bonnet**

Nenndruck / Nominal pressure PN16

Art.Nr. 20.01.01 Form A Durchgangsform / *straight type*

Art.Nr. 20.01.02 Form B Eckform / *angle*

Verwendungsbereich:

Geeignet für Dampf, Luft, Kalt- und Heißbrauchwasser, Öl (Heiz-, Treib- und Schmieröl) und andere neutrale Flüssigkeiten.

Verwendbar für Temperaturen bis 300°C

Zulässige Betriebstemperaturen und -drücke:

bis 120°C	max. 16 bar
150°C	14 bar
200°C	13 bar
250°C	11 bar
300°C	9,5 bar

Sonderausführungen:

- ◇ Gehäuse und Deckel aus GP240 GH, EN-GJS-400-18-LT
- ◇ Innenteile aus Bronze
- ◇ DN 15 – DN 200 PN 6, PN25, PN40
- ◇ DN 15 – DN 300 PN10
- ◇ Flansche nach ANSI, BS usw. auf Anfrage
- ◇ Regulierkegel
- ◇ Entlastungskegel DN 200 – DN 300
- ◇ Anzeigevorrichtung
- ◇ Kegeldichtung PTFE (max. 200°C)

Wesentliche Vorteile:

- ◇ hoher Dichtheitsgrad
- ◇ kompakte Bauweise
- ◇ wartungsfrei
- ◇ umweltfreundlich

Application:

Suitable for steam, air, industrial cold and hot water, oil (fuel oil, diesel oil, lubricating oil) and other neutral fluids.

Application for temperatures up to 300°C

Admissible temperatures and pressures:

up to 120°C	max. 16 bar
150°C	14 bar
200°C	13 bar
250°C	11 bar
300°C	9,5 bar

Special design:

- ◇ body and bonnet material GP240 GH, EN-GJS-400-18-LT
- ◇ innerparts material bronze
- ◇ DN 15 – DN 200 PN 6, PN25, PN40
- ◇ DN 15 – DN 300 PN10
- ◇ Flanges acc. ANSI, BS etc. on request
- ◇ regulating disc
- ◇ balanced disc DN 200 – DN 300
- ◇ Indicator
- ◇ disc sealing PTFE (max. 200°C)

Main advantages:

- ◇ high tightness
- ◇ compact construction
- ◇ no maintenance
- ◇ environmentally friendly

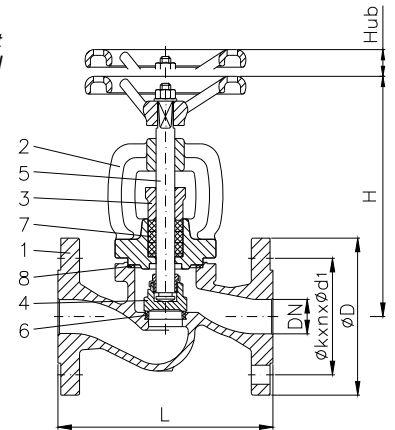

Art.Nr. 20.01.01

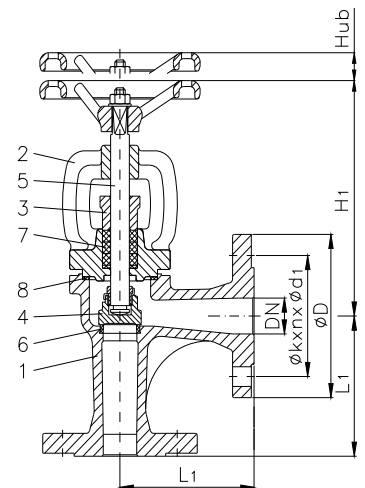

Art.Nr. 20.01.02

Teil Part	Bezeichnung Name	Werkstoff nach DIN/EN Material acc. to DIN/EN	Werkstoff nach USA Material acc. to USA
1	Gehäuse / body	EN-GJL-250	A48 (40B) (ASTM)
2	Bügeldeckel / bonnet	EN-GJL-250	A48 (40B) (ASTM)
3	Stopfbuchse / gland	DN 15 - 32 EN-GJS-500-7 DN 40 - 300 EN-GJL-250	A536 (60-45-12) (ASTM) A48 (40B) (ASTM)
4	Kegel / disc	X20Cr 13	420 (AISI)
5	Spindel / stem	X20Cr 13	420 (AISI)
6	Sitzring / seat ring	X12Cr 13	410 (AISI)
7	Stopfbuchspackung / gland packing	Reingraphit	---
8	Deckeldichtung / bonnet sealing	Graphit / CrNiSt	---

Flansch / flange

DN	PN10			PN16			L	L1	H	H1	Hub	Form A ≈ kg	Form B ≈ kg
	Ø D	Ø k x n x Ø d1	Ø D	Ø k x n x Ø d1									
15	95	65 x 4 x 14	95	65 x 4 x 14	130	90	167	163	5				
20	105	75 x 4 x 14	105	75 x 4 x 14	150	95	167	160	6				
25	115	85 x 4 x 14	115	85 x 4 x 14	160	100	175	173	7				
32	140	100 x 4 x 19	140	100 x 4 x 19	180	105	186	173	14				
40	150	110 x 4 x 19	150	110 x 4 x 19	200	115	235	214	20				
50	165	125 x 4 x 19	165	125 x 4 x 19	230	125	248	211	25				
65	185	145 x 4 x 19	185	145 x 4 x 19	290	145	260	236	35				
80	200	160 x 8 x 19	200	160 x 8 x 19	310	155	291	250	41				
100	220	180 x 8 x 19	220	180 x 8 x 19	350	175	338	301	31				
125	250	210 x 8 x 19	250	210 x 8 x 19	400	200	384	339	48				
150	285	240 x 8 x 23	285	240 x 8 x 23	480	225	429	383	54				
200	340	295 x 8 x 23	340	295 x 12 x 23	600	275	529	455	77				
250	395	350 x 12 x 23	405	355 x 12 x 28	730	325	638	531	120				
300	445	400 x 12 x 23	460	410 x 12 x 28	850	375	710	710	120				