

Flanschen-Rückschlagventil, absperrbar DIN 86261, Rg 5/SoMs 59 mit Bügeldeckel
 Flanschen ANSI 150 lbs rf

Screw-down stop and check valve, flanged DIN 86261, gunmetal/SoMs 59 with bolted bonnet, flanged ANSI 150 lbs rf

Nenndruck / Nominal pressure

DN 15 – DN 125 **PN16** DN 150 – DN 200 **PN10** DN 250 – DN 300 **PN 6** DN 350 – DN 500 **PN 4**

Art.Nr. 20.02.01 Form A Durchgangsform / *straight type*

Art.Nr. 20.02.02 Form B Eckform / *angle type*

Verwendungsbereich:

Geeignet für kaltes und heißes Wasser, Satt-
 dampf, Öl und andere neutrale, nicht aggressive
 Medien.

Bei Verwendung für dünnflüssige Medien
 oder Luft ist ein Sondereinschliff der Dicht-
 flächen erforderlich.

(Bitte Art, Druck und Temperatur des
 Mediums angeben.)

Verwendbar für Temperaturen bis 225°C
 (Dampf bis 180°C)

**Zulässige Betriebstemperaturen
 und -drücke:**

max. Druck	bis 120°C	über 120°C
DN 15 - 125	16 bar	10 bar
DN 150 - 200	10 bar	6 bar
DN 250 - 300	6 bar	4 bar
DN 350 - 500	4 bar	2 bar

Application:

Suitable for cold and hot water, saturated
 steam, oil and other neutral non aggressive
 liquids.

For the application for highfluid liquids or air
 a special sealing surface is necessary.

(Please inform us about type of the liquid,
 pressure and temperature.)

Application for temperatures up to 225°C
 (steam up to 180°C)

Admissible temperatures and pressures:

max. pressure	up to 120°C	over 120°C
DN 15 - 125	16 bar	10 bar
DN 150 - 200	10 bar	6 bar
DN 250 - 300	6 bar	4 bar
DN 350 - 500	4 bar	2 bar

Sonderausführungen:

- ◇ Kegel mit auswechselbarer Dichtung
 (PTFE, NBR usw.)
- ◇ Spindel aus CuSn 6, CuAl10 Ni usw.
- ◇ Ventile aus G-CuSn10 Zn, CuSn10-C usw.
- ◇ Ventile Ausführung: Rg 03 und Gbz 03 mit
 Sitzring aus CuAl10 Ni usw.
- ◇ Ventile PN 6, 25, 40 usw.
- ◇ Ventile mit Schließfeder

Special design:

- ◇ Disc with exchangeable sealing
 (PTFE, NBR, etc.)
- ◇ Stem material CuSn 6, CuAl10 Ni etc.
- ◇ Valves mat. G-CuSn10 Zn, CuSn10-C etc.
- ◇ Valves design acc. Rg 03 and Gbz 03 with
 seat ring in CuAl10 Ni etc.
- ◇ Valves PN 6, 25, 40 etc.
- ◇ Valves with spring

Teil Part	Bezeichnung Name	Werkstoff nach DIN Material acc. to DIN	Werkstoff nach BS Material acc. to BS
1	Gehäuse / body	CuSn5Zn5Pb5-C	B.S.1400:1961 LG 2-C
2	Bügeldeckel / bonnet	CuSn5Zn5Pb5-C	B.S.1400:1961 LG 2-C
3	Kegel / disc	bis DN 32 ab DN 40 CuZn35 Ni CuSn5Zn5Pb5-C	B.S.2874:1962 CZ 114 B.S.1400:1961 LG 2-C
4	Spindel / stem	CuZn35 Ni	B.S.2874:1962 CZ 114
6	Deckeldichtung / bonnet sealing	FA1 / asbestfrei	---
7	Handrad / handwheel	EN-GJL-250, schwarz lackiert	B.S.1452:1990 Gr.150/180

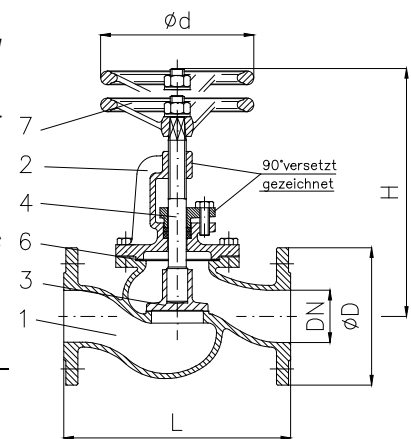

Art.Nr. 20.02.01

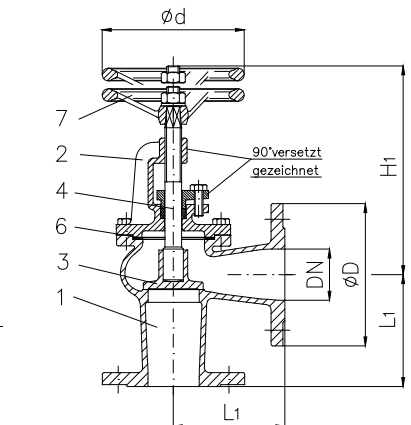

Art.Nr. 20.02.02

Flansch / flange								
DN	Ø D	Ø k x n x Ø d1	L	L1	H	H1	Ø d	Hub
15	88,9	60,3 x 4 x 15,9	130	90	180	160	100	6
20	98,4	69,8 x 4 x 15,9	150	95	200	170	100	7
25	108,0	79,4 x 4 x 15,9	160	100	310	170	100	8
32	117,5	88,9 x 4 x 15,9	180	105	220	190	125	10
40	127,0	98,4 x 4 x 15,9	200	115	250	210	160	12
50	152,4	120,6 x 4 x 19,0	230	125	250	220	160	15
65	177,8	139,7 x 4 x 19,0	290	145	315	260	200	19
80	190,5	152,4 x 4 x 19,0	310	155	335	280	200	24
100	228,6	190,5 x 8 x 19,0	350	175	360	300	250	27
125	254,0	215,9 x 8 x 22,2	400	200	405	340	250	32
150	279,4	241,3 x 8 x 22,2	480	225	460	360	315	40
200	342,9	298,4 x 8 x 22,2	600	275	550	440	400	56
250	406,4	361,9 x 12 x 25,4	730	325	670	550	400	65
300	482,6	431,8 x 12 x 25,4	850	375	750	620	400	80
350	533,4	476,2 x 12 x 28,6	980	425	850	720	500	90
400	596,9	539,8 x 16 x 28,6	1100	475	910	750	500	105
450	635,0	577,9 x 16 x 31,7	1200	500	970	925	500	115
500	698,5	635,0 x 20 x 31,7	1250	590	1095	950	500	130

Form A		Form B	
kv	≈ kg	kv	≈ kg
6	5,0	7	3,8
8	5,5	10	4,0
11	6,0	15	5,0
17	8,0	27	7,0
29	10,0	39	9,0
47	12,0	71	11,0
78	17,0	108	16,0
114	23,0	150	20,0
192	30,0	235	25,0
234	50,0	360	40,0
410	65,0	510	50,0
725	110,0	905	95,0
1145	165,0	1430	155,0
1635	295,0	2040	225,0
2220	480,0	2775	360,0
3180	510,0	3975	400,0
3659	1150,0	4600	650,0
4530	1300,0	5660	800,0