

Flanschen-Absperrventil DIN 86260, Gbz 10/CuSn 6

mit Bügeldeckel, Flanschen ANSI 150 lbs rf

Stop valve DIN 86260, zincfree bronze/CuSn 6

with bolted bonnet, flanged ANSI 150 lbs rf

Nenndruck / Nominal pressure

DN 15 – DN 125 **PN16** DN 150 – DN 200 **PN10** DN 250 – DN 300 **PN 6** DN 350 – DN 500 **PN 4**

Art.Nr. 20.01.01 Form A Durchgangsform / *straight type*

Art.Nr. 20.01.02 Form B Eckform / *angle type*

Verwendungsbereich:

Geeignet für kaltes und heißes Wasser, Satteldampf, Öl und andere neutrale, nicht aggressive Medien.

Bei Verwendung für dünnflüssige Medien oder Luft ist ein Sondereinschliff der Dichtflächen erforderlich.

(Bitte Art, Druck und Temperatur des Mediums angeben.)

Verwendbar für Temperaturen bis 225°C (Dampf bis 180°C)

Zulässige Betriebstemperaturen und -drücke:

max. Druck	bis 120°C	über 120°C
DN 15 - 125	16 bar	10 bar
DN 150 - 200	10 bar	6 bar
DN 250 - 300	6 bar	4 bar
DN 350 - 500	4 bar	2 bar

Sonderausführungen:

- ◇ Kegel mit auswechselbarer Dichtung (PTFE, NBR usw.)
- ◇ Regulierkegel
- ◇ Spindel aus CuZn35 Ni, CuAl10 Ni usw.
- ◇ Ventile Ausführung: Rg 03 und Gbz 03 mit Sitzring aus CuAl10 Ni usw.
- ◇ Ventile PN 6, 16, 25, 40 usw.

Application:

Suitable for cold and hot water, saturated steam, oil and other neutral non aggressive liquids.

For the application for high fluid liquids or air a special sealing surface is necessary.

(Please inform us about type of the liquid, pressure and temperature.)

Application for temperatures up to 225°C (steam up to 180°C)

Admissible temperatures and pressures:

max. pressure	up to 120°C	over 120°C
DN 15 - 125	16 bar	10 bar
DN 150 - 200	10 bar	6 bar
DN 250 - 300	6 bar	4 bar
DN 350 - 500	4 bar	2 bar

Special design:

- ◇ Disc with exchangeable sealing (PTFE, NBR etc.)
- ◇ Regulate disc
- ◇ Stem material CuZn35 Ni, CuAl10 Ni etc.
- ◇ Valves design acc. Rg 03 and Gbz 03 with seat ring in CuAl10 Ni etc.
- ◇ Valves PN 6, 16, 25, 40 etc.

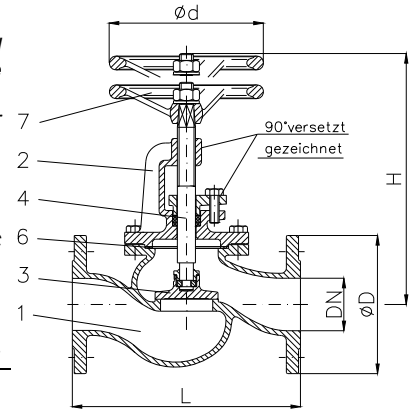

Art.Nr. 20.01.01

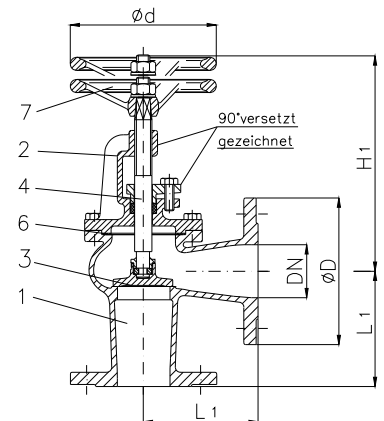

Art.Nr. 20.01.02

Teil Part	Bezeichnung Name	Werkstoff nach DIN Material acc. to DIN	Werkstoff nach BS Material acc. to BS
1	Gehäuse / body	CuSn10-C	B.S.1400:1961 PB 4-C
2	Bügeldeckel / bonnet	CuSn10-C	B.S.1400:1961 PB 4-C
3	Kegel / disc	bis DN 32 CuAl10 Ni ab DN 40 CuSn10-C	B.S.2032:1963 CA 103 B.S.1400:1961 PB 4-C
4	Spindel / stem	CuSn 6	B.S.2874:1962 PB 103
5	Deckeldichtung / bonnet sealing	FA1 / asbestfrei	---
6	Handrad / handwheel	EN-GJ-250, schwarz lackiert	B.S.1452:1990 Gr.150/180

Flansch / flange									
DN	Ø D	Ø k x n x Ø d1	L	L1	H	H1	Ø d	Hub	
15	88,9	60,3 x 4 x 15,9	130	90	180	160	100	6	
20	98,4	69,8 x 4 x 15,9	150	95	200	170	100	7	
25	108,0	79,4 x 4 x 15,9	160	100	210	170	100	8	
32	117,5	88,9 x 4 x 15,9	180	105	220	190	125	10	
40	127,0	98,4 x 4 x 15,9	200	115	250	210	160	12	
50	152,4	120,6 x 4 x 19,0	230	125	250	220	160	15	
65	177,8	139,7 x 4 x 19,0	290	145	315	260	200	19	
80	190,5	152,4 x 4 x 19,0	310	155	335	280	200	24	
100	228,6	190,5 x 8 x 19,0	350	175	375	300	250	28	
125	254,0	215,9 x 8 x 22,2	400	200	420	340	250	36	
150	279,4	241,3 x 8 x 22,2	480	225	460	360	315	40	
200	342,9	298,4 x 8 x 22,2	600	275	550	440	400	56	
250	406,4	361,9 x 12 x 25,4	730	325	670	550	400	65	
300	482,6	431,8 x 12 x 25,4	850	375	750	620	400	80	
350	533,4	476,2 x 12 x 28,6	980	425	850	720	500	90	
400	596,9	539,8 x 16 x 28,6	1100	475	910	750	500	105	
450	635,0	577,9 x 16 x 31,7	1200	500	970	925	500	115	
500	698,5	635,0 x 20 x 31,7	1250	590	1095	950	500	130	

Form A		Form B	
kv	≈ kg	kv	≈ kg
6	5,0	7	3,8
8	5,5	10	4,0
11	6,0	15	5,0
17	8,0	27	7,0
29	10,0	39	9,0
47	12,0	71	11,0
78	17,0	108	16,0
114	23,0	150	20,0
192	30,0	235	25,0
234	50,0	360	40,0
410	65,0	510	50,0
725	110,0	905	95,0
1145	165,0	1430	155,0
1635	295,0	2040	225,0
2220	480,0	2775	360,0
3180	510,0	3975	400,0
3659	1150,0	4600	650,0
4530	1300,0	5660	800,0