



## Z601B

### BRONZE GATE VALVE

Outside Screw & York - Rising Stem - Bronze Trim

Cast Bronze Wedge Gate Valve. Outside Screw and Yoke., Bolted Cover & Gland, Rising Stem, Solid Bronze Wedge, Integral Seats.  
Flanged to AS2129. Table "E".

#### PRESSURE/TEMPERATURE RATING

Max Service Temp 170°C (338°F)  
Water, Oil or Gas up to 1400KPA (200PSI)

#### OPTIONS

Screwed in Body Seat Rings available upon request.  
Valves manufactured in other flange and body material specifications on request.

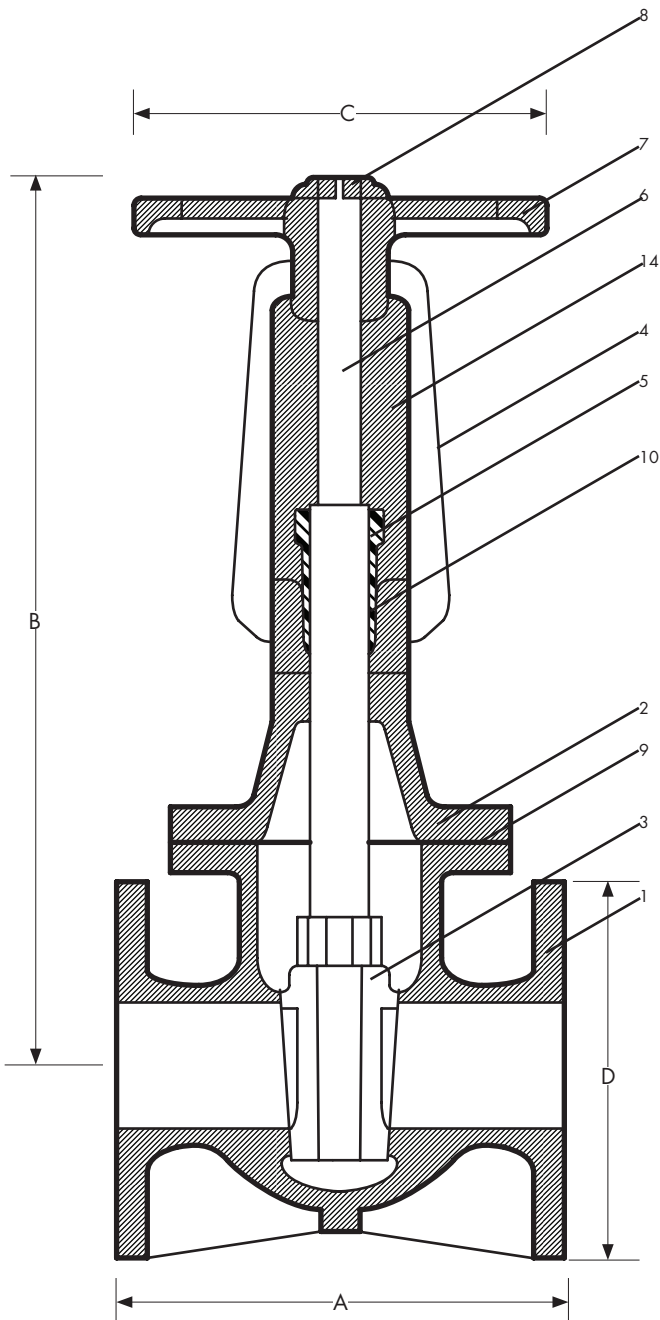

#### DIMENSIONS - mm

Size	32	40	50	65	80	100	125	150	200	250
A	114	117	143	156	171	210	215	215	292	330
B (open)	305	381	457	457	483	610	690	864	950	1120
C	127	127	127	152	175	200	250	250	305	350
D	115	120	135	165	185	215	254	279	337	406

Dimensions for larger sizes are available on request.

#### MATERIAL SPECIFICATIONS

REF	Component	Material	AS or BS Specification
1	Body	Cast Bronze LG2	AS 1565- C83600
2	Cover	Cast Bronze LG2	AS 1565- C83600
3	Wedge	Cast Bronze LG2	AS 1565- C83600
4	Bridge	Cast Bronze LG2	AS 1565- C83600
5	Gland	Cast Bronze LG2	AS 1565- C83600
6	Spindle	DR: Brass	AS 1567-352
7	Handwheel	Cast Iron	AS 1830
8	Handwheel Nut	Stainless Steel	-
9	Gasket	Klinger	K'Sil 4430
10	Packing	PTFE	Klinger K10
11	Cover Bolts	304 Stainless Steel	-
12	Cover Nuts	316 Stainless Steel	-
13	Gland Nuts	316 Stainless Steel	-
14	Yoke Sleeve	Cast Bronze LG2	AS 1565- C83600

Document Version | April 2014