

JISF7369 16K CAST IRON NON-RISING STEM GATE VALVE WITH BRASS INDICATOR

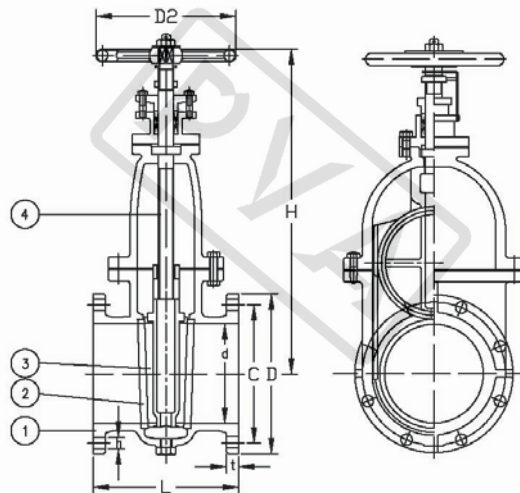

Pressure Test MPa			
Nominal Pressure/PN	1.6MPa	Shell Test	2.4MPa
		Seat Test	1.8MPa

Main material for fittings			
Item	Fittings	Material	Mark
1	Body	Cast Iron	FC200
2	Bonnet	Cast Iron	FC200
3	Wedge	Cast Iron	FC200
4	Seat	Stainless Steel/Cast Bronze	SS420/BC6
5	Stem	Stainless Steel/Forged Brass	SS400/C3771BD
6	Handwheel	Cast Iron	FC200

Main data for flange connection						mm
Model	Face To Face	Flange Diam.	Flange PCD	Flange Hole	Height	Weight
	L1	D	C	n* ϕ d	H	kgs
F7369 16K50	200	155	120	8 \times ϕ 19	300	20.40
F7369 16K65	220	175	140	8 \times ϕ 19	350	30.40
F7369 16K80	234	200	160	8 \times ϕ 23	400	36.30
F7369 16K100	254	225	185	8 \times ϕ 23	450	54.40
F7369 16K125	274	270	225	8 \times ϕ 25	520	72.50
F7369 16K150	294	305	260	12 \times ϕ 25	580	94.60
F7369 16K200	328	350	305	12 \times ϕ 25	700	149.60
F7369 16K250	388	430	380	12 \times ϕ 27	840	243.50
F7369 16K300	490	480	430	16 \times ϕ 27	1010	430.00

Design	Check	Signature	Logo	Supplier
asbsey	Chrit	Figor		PROMET VALVES AUSTRALIA
JAN.01,2013	JAN.01,2013	JAN.01,2013		

PROMET VALVES AUSTRALIA

1A Green Road Woodville West SA 5011 Australia / Tel:+61 8 8268 1777 / Fax:+61 8 8268 1711
 promet@prometvalves.com / www.prometvalves.com / ABN 47 096 425 697