

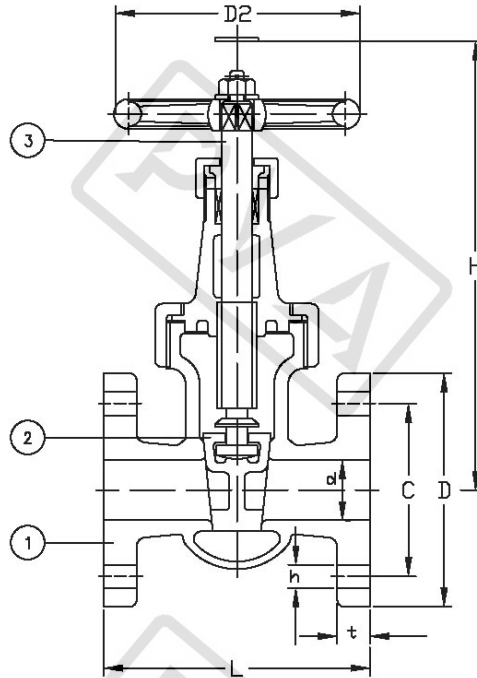

JISF7368 10K CAST BRONZE RISING STEM GATE VALVE



		Pressure Test MPa	
Nominal Pressure/PN	1.0MPa	Shell Test	2.1MPa
		Seat Test	1.54MPa

Main material for fittings			
Item	Fittings	Material	Mark
1	Body	Cast Bronze	BC6
2	Bonnet	Cast Bronze	BC6
3	Disc	Cast Bronze	BC6
4	Seat	Cast Bronze	BC6
5	Stem	Forged Brass	C3771BD
6	Handwheel	Cast Iron	FC200

Main data for flange connection						mm
Model	Face To Face	Flange Diam.	Flange PCD	Flange Hole	Height	Weight
	L1	D	C	n* ϕ d	H	kgs
F7368 10K15	100	95	70	4 \times ϕ 15	175	2.96
F7368 10K20	110	100	75	4 \times ϕ 15	200	3.89
F7368 10K25	120	125	90	4 \times ϕ 19	220	5.82
F7368 10K32	140	135	100	4 \times ϕ 19	250	7.52
F7368 10K40	150	140	105	4 \times ϕ 19	290	9.71
F7368 10K50	200	155	120	4 \times ϕ 19	340	19.40
F7368 10K65	220	175	140	4 \times ϕ 19	360	27.60

Design	Check	Signature	Logo	Supplier
asbsey	Chrit	Figor		PROMET VALVES AUSTRALIA
JAN.01,2013	JAN.01,2013	JAN.01,2013		

PROMET VALVES AUSTRALIA

1A Green Road Woodville West SA 5011 Australia / Tel:+61 8 8268 1777 / Fax:+61 8 8268 1711
 promet@prometvalves.com / www.prometvalves.com / ABN 47 096 425 697