

JISF7364 10K CAST IRON NON-RISING STEM GATE VALVE WITH BRASS INDICATOR

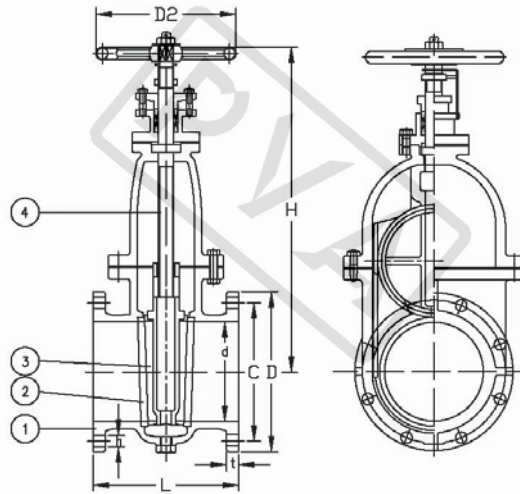

| Pressure Test MPa | | | |
|---------------------|--------|------------|---------|
| Nominal Pressure/PN | 1.0MPa | Shell Test | 2.1MPa |
| | | Seat Test | 1.54MPa |

| Main material for fittings | | | |
|----------------------------|-----------|------------------------------|---------------|
| Item | Fittings | Material | Mark |
| 1 | Body | Cast Iron | FC200 |
| 2 | Bonnet | Cast Iron | FC200 |
| 3 | Wedge | Cast Iron | FC200 |
| 4 | Seat | Stainless Steel/Cast Bronze | SS420/BC6 |
| 5 | Stem | Stainless Steel/Forged Brass | SS400/C3771BD |
| 6 | Handwheel | Cast Iron | FC200 |

| Main data for flange connection | | | | | | mm |
|---------------------------------|--------------|--------------|------------|-----------------------|--------|--------|
| Model | Face To Face | Flange Diam. | Flange PCD | Flange Hole | Height | Weight |
| | L1 | D | C | n* ϕ d | H | kgs |
| F7364 10K50 | 200 | 155 | 120 | 4 \times ϕ 19 | 300 | 19.40 |
| F7364 10K65 | 220 | 175 | 140 | 4 \times ϕ 19 | 350 | 27.60 |
| F7364 10K80 | 230 | 185 | 150 | 8 \times ϕ 19 | 400 | 33.00 |
| F7364 10K100 | 250 | 210 | 175 | 8 \times ϕ 19 | 450 | 45.80 |
| F7364 10K125 | 270 | 250 | 210 | 8 \times ϕ 23 | 520 | 65.90 |
| F7364 10K150 | 290 | 280 | 240 | 8 \times ϕ 23 | 580 | 86.00 |
| F7364 10K200 | 320 | 330 | 290 | 12 \times ϕ 23 | 700 | 136.00 |
| F7364 10K250 | 380 | 400 | 355 | 12 \times ϕ 25 | 840 | 230.00 |
| F7364 10K300 | 440 | 445 | 400 | 16 \times ϕ 25 | 960 | 331.00 |
| F7364 10K350 | 500 | 490 | 445 | 16 \times ϕ 25 | 1050 | 433.00 |
| F7364 10K400 | 590 | 560 | 510 | 16 \times ϕ 27 | 1150 | 597.00 |

| Design | Check | Signature | Logo | Supplier |
|-------------|-------------|-------------|------|--------------------------------|
| asbsey | Chrit | Figor | | PROMET VALVES AUSTRALIA |
| JAN.01,2013 | JAN.01,2013 | JAN.01,2013 | | |

PROMET VALVES AUSTRALIA

1A Green Road Woodville West SA 5011 Australia / Tel:+61 8 8268 1777 / Fax:+61 8 8268 1711
 promet@prometvalves.com / www.prometvalves.com / ABN 47 096 425 697