

# JISF7363 5K CAST IRON NON-RISING STEM GATE VALVE WITH BRASS INDICATOR

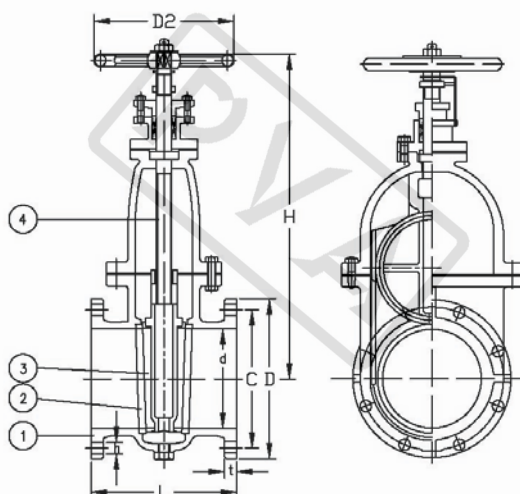

Pressure Test MPa			
Nominal Pressure/PN	0.5MPa	Shell Test	1.05MPa
		Seat Test	0.75MPa

Main material for fittings			
Item	Fittings	Material	Mark
1	Body	Cast Iron	FC200
2	Bonnet	Cast Iron	FC200
3	Wedge	Cast Iron	FC200
4	Seat	Stainless Steel/Cast Bronze	SS420/BC6
5	Stem	Stainless Steel/Forged Brass	SS400/C3771BD
6	Handwheel	Cast Iron	FC200

Main data for flange connection						mm
Model	Face To Face	Flange Diam.	Flange PCD	Flange Hole	Height	Weight
	L1	D	C	n* $\phi$ d	H	kgs
F7363 5K50	180	130	105	4 $\times$ $\phi$ 15	285	13.50
F7363 5K65	190	155	130	4 $\times$ $\phi$ 15	330	19.00
F7363 5K80	200	180	145	4 $\times$ $\phi$ 19	380	24.20
F7363 5K100	230	200	165	8 $\times$ $\phi$ 19	430	35.30
F7363 5K125	250	235	200	8 $\times$ $\phi$ 19	495	48.10
F7363 5K150	270	265	230	8 $\times$ $\phi$ 19	560	65.30
F7363 5K200	290	320	280	8 $\times$ $\phi$ 23	680	103.00
F7363 5K250	330	385	345	12 $\times$ $\phi$ 23	800	164.00
F7363 5K300	370	430	390	12 $\times$ $\phi$ 23	920	236.00
F7363 5K350	410	480	435	12 $\times$ $\phi$ 25	1000	307.00
F7363 5K400	470	540	495	16 $\times$ $\phi$ 25	1100	405.00

Design	Check	Signature	Logo	Supplier
asbsey	Chrit	Figor		<b>PROMET VALVES AUSTRALIA</b>
JAN.01,2013	JAN.01,2013	JAN.01,2013		

**PROMET VALVES AUSTRALIA**

1A Green Road Woodville West SA 5011 Australia / Tel:+61 8 8268 1777 / Fax:+61 8 8268 1711  
 promet@prometvalves.com / www.prometvalves.com / ABN 47 096 425 697