

Z404B

CAST BRONZE SWING CHECK VALVE

Integrated Bonnet - Balanced Hinge Assembly

An AS 2129 E flanged cast bronze swing check valve with bolted cover and replaceable seat from 65mm and up.

PRESSURE/TEMPERATURE RATING

Steam up to 700KPA (100PSI)
 Max Service Temp 170°C (338°F)
 Water, Oil or Gas up to 1400KPA (200PSI)

OPTIONS

Also available on request with extended spindle or counter lever and weight.
 Modifications available upon request.

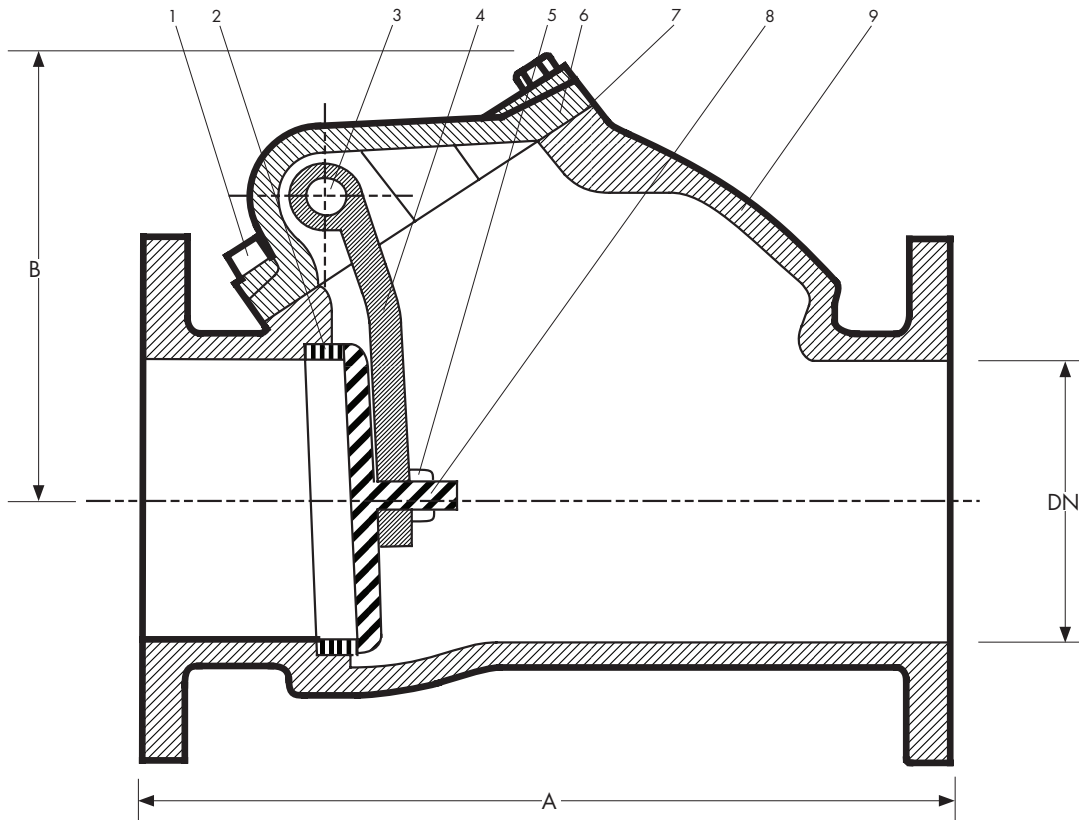

DIMENSIONS - mm								
Size (DN)	40	50	65	80	100	125	150	200
A	187	240	260	260	330	410	410	540
B	105	110	135	150	165	205	225	280
Mass kg	7	10	18.5	22	27	55	67	120

Dimensions for larger sizes are available on request.

MATERIAL SPECIFICATIONS			
REF	Component	Material	AS or BS Specification
1	Fasteners	Stainless Steel	316 S/S
2	Seat	Cast Bronze LG2	AS 1565-C83600
3	Hinge Pin	DR. Brass	AS 1567-352
4	Hinge	Cast Bronze LG2	AS 1565-C83600
5	Lock Nut	Stainless Steel	316 S/S
6	Cover	Cast Bronze LG2	AS 1565-C83600
7	Gasket	Klinger	K'Sil 4430
8	Flap/Disk	Cast Bronze LG2	AS 1565-C83600
9	Body	Cast Bronze LG2	AS 1565-C83600
10	Plug	DR. Brass	AS 1567-352