

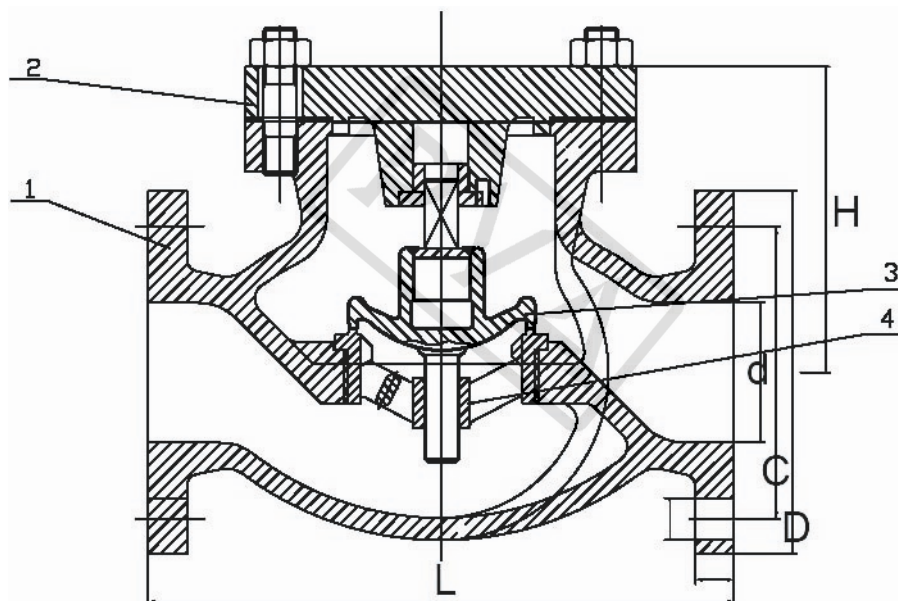

# JISF7358 5K CAST IRON LIFT CHECK GLOBE VALVE



Pressure Test MPa			
Nominal Pressure/PN	0.5MPa	Shell Test	0.76MPa
		Seat Test	1.05MPa

Main material for fittings			
Item	Fittings	Material	Mark
1	Body	Cast Iron	FC200
2	Bonnet	Cast Iron	FC200
3	Disc	Stainless Steel/Cast Bronze	SS420/BC6
4	Seat	Stainless Steel/Cast Bronze	SS420/BC6

Main data for flange connection mm						
Model	Face To Face	Flange Diam.	Flange PCD	Flange Hole	Height	Weight
	L	D	C	n* $\varnothing$ d	H	kgs
F7358 5K50	210	130	105	4 $\times$ $\varnothing$ 15	107	11.30
F7358 5K65	250	155	135	4 $\times$ $\varnothing$ 15	124	16.80
F7358 5K80	280	180	145	4 $\times$ $\varnothing$ 19	129	23.20
F7358 5K100	340	200	165	8 $\times$ $\varnothing$ 19	146	32.50
F7358 5K125	410	235	200	8 $\times$ $\varnothing$ 19	166	48.10
F7358 5K150	480	265	230	8 $\times$ $\varnothing$ 19	188	67.90

Design	Check	Signature	Logo	Supplier
asbsey	Chrit	Figor		PROMET VALVES AUSTRALIA
JAN.01,2013	JAN.01,2013	JAN.01,2013		

## PROMET VALVES AUSTRALIA

1A Green Road Woodville West SA 5011 Australia / Tel:+61 8 8268 1777 / Fax:+61 8 8268 1711  
 promet@prometvalves.com / www.prometvalves.com / ABN 47 096 425 697