

## Absperrklappe zum Anflanschen, GGG 40.3/Al-Bronze mit vulkanisierter Dichtung, Getriebe

**Butterfly valve lug type, nodular cast iron/Al-bronze  
back seated, gear box**

Nennndruck / Nominal pressure PN10

Art.Nr. 50.63.03

### Verwendungsbereich:

Geeignet für kaltes und heißes Wasser, Öl und andere neutrale, nicht aggressive Medien.

Verwendbar für Temperaturen bis 135°C

### Temperaturbereiche:

NBR -12°C bis +82°C

EPDM -35°C bis +120°C

FPM -12°C bis +135°C

### Technische Merkmale:

Konzentrisch gelagerte, weichdichtende Absperrklappe zum Einbau zwischen Flansche nach DIN, ANSI, JIS usw.

### Wesentliche Vorteile:

Absolut dichtschießend in beiden Durchflußrichtungen.

### Sonderausführungen:

- ◇ Gehäuse aus Al-Bronze, GP240 GH, EN-GJL-250
- ◇ Sitz aus EPDM, FPM
- ◇ Klappenscheibe aus Niro

### Application:

Suitable for cold and hot water, oil and other neutral, non aggressive medium.

Application for temperatures up to 135°C

### Temperature range:

NBR -12°C up to +82°C

EPDM -35°C up to +120°C

FPM -12°C up to +135°C

### Technical features:

Concentric disc, soft sealing butterfly valve for installation between flanges drilled in accordance with DIN, ANSI, JIS etc.

### Main advantages:

Absolutely tight sealing with flow in both directions.

### Special design:

- ◇ body material Al-bronze, GP240 GH, EN-GJL-250
- ◇ seat material EPDM, FPM
- ◇ disc material stainless steel

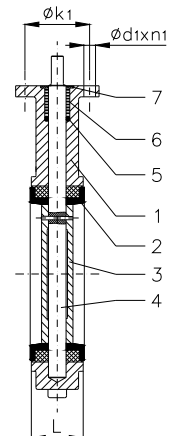
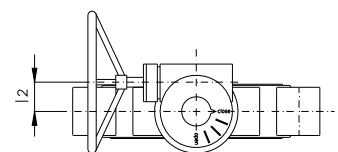
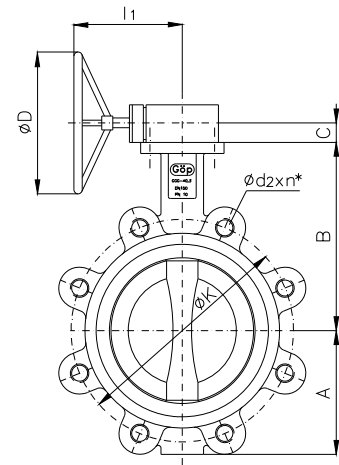

Teil Part	Bezeichnung Name	Werkstoff nach DIN Material acc. to DIN	Werkstoff nach ANSI Material acc. to ANSI
1	Gehäuse / body	EN-GJS-400-18-LT	A536 (60-40-18) (ASTM)
2	Sitz / seat	NBR	---
3	Klappenscheibe / disc	Al-Bronze	---
4	Welle / shaft	X6CrNiMoTi17-12-2	316 Ti (AISI)
5	Dichtring / sealing ring	NBR	---
6	Buchse / bushing	Azetel	---
7	Unterlegscheibe / washer	Bronze	---

### Flansch / flange

DN	A	B	C	Ø D	PN 6			PN10			PN16			≈ kg
					Ø K x n* x Ø d2	Ø K x n* x Ø d2	Ø K x n* x Ø d2	Ø K x n* x Ø d2	Ø K x n* x Ø d2	Ø K x n* x Ø d2	Ø k1 x n1 x Ø d1	L	I1	
40	61	130	38	152	100 x 4 x M12	110 x 4 x M16	110 x 4 x M16	70 x 4 x 10	33	154	45	7,3		
50	83	124	38	152	110 x 4 x M12	125 x 4 x M16	125 x 4 x M16	70 x 4 x 10	43	154	45	7,9		
65	89	134	38	152	130 x 4 x M12	145 x 4 x M16	145 x 4 x M16	70 x 4 x 10	46	154	45	8,2		
80	95	141	39	300	150 x 4 x M16	160 x 8 x M16	160 x 8 x M16	70 x 4 x 10	46	238	63	17,2		
100	114	156	39	300	170 x 4 x M16	180 x 8 x M16	180 x 8 x M16	70 x 4 x 10	52	238	63	18,6		
125	127	170	39	300	200 x 8 x M16	210 x 8 x M16	210 x 8 x M16	70 x 4 x 10	56	238	63	20,6		
150	140	186	39	300	225 x 8 x M16	240 x 8 x M20	240 x 8 x M20	70 x 4 x 10	56	238	63	21,9		
200	175	218	45	300	280 x 8 x M16	295 x 8 x M20	295 x 12 x M20	102 x 4 x 12	60	222	78	29,9		
250	220	249	45	300	335 x 12 x M16	350 x 12 x M20	355 x 12 x M24	102 x 4 x 12	68	222	78	33,1		
300	253	285	45	300	395 x 12 x M20	400 x 12 x M20	410 x 12 x M24	125 x 4 x 14	78	222	78	45,9		
350	279	320	45	300	445 x 12 x M20	460 x 16 x M20	470 x 16 x M24	125 x 4 x 14	92	222	78	58,1		
400	305	350	50	300	495 x 16 x M20	515 x 16 x M24	525 x 16 x M27	165 x 4 x 22	102	300	120	88,0		
450	365	380	50	300	550 x 16 x M20	565 x 20 x M24	585 x 20 x M27	165 x 4 x 22	114	300	120	108,0		
500	371	420	64	400	600 x 20 x M20	620 x 20 x M24	650 x 20 x M30	165 x 4 x 22	127	350	120	179,0		
600	457	470	70	400	705 x 20 x M24	725 x 20 x M27	770 x 20 x M33	165 x 4 x 22	154	350	120	253,0		

Mögliche Getriebe-Positionen. Die Standard-Ausführung ist Typ 1. / Possible gear box positions. The standard execution is type 1.

