

Absperrklappe zum Einklemmen, GGG 40.3/Niro mit vulkanisierter Dichtung, Getriebe

**Butterfly valve wafer type, nodular cast iron/stainless steel
back seated, gear box**

Nennndruck / Nominal pressure PN10

Art.Nr. 50.61.03

Verwendungsbereich:

Geeignet für kaltes und heißes Wasser, Kraftstoff, Öl und andere neutrale, nicht aggressive Medien.

Verwendbar für Temperaturen bis 135°C

Temperaturbereiche:

NBR -12°C bis +82°C

EPDM -35°C bis +120°C

FPM -12°C bis +135°C

Technische Merkmale:

Konzentrisch gelagerte, weichdichtende Absperrklappe zum Einbau zwischen Flansche nach DIN, ANSI, JIS usw.

Wesentliche Vorteile:

Absolut dichtschießend in beiden Durchflußrichtungen.

Sonderausführungen:

- ◇ Gehäuse aus Al-Bronze, GP240 GH, EN-GJL-250
- ◇ Sitz aus EPDM, FPM
- ◇ Klappenscheibe aus Al-Bronze

Application:

Suitable for cold and hot water, fuel-oil, oil and other neutral, non aggressive medium.

Application for temperatures up to 135°C

Temperature range:

NBR -12°C up to +82°C

EPDM -35°C up to +120°C

FPM -12°C up to +135°C

Technical features:

Concentric disc, soft sealing butterfly valve for installation between flanges drilled in accordance with DIN, ANSI, JIS etc.

Main advantages:

Absolutely tight sealing with flow in both directions.

Special design:

- ◇ body material Al-bronze, GP240 GH, EN-GJL-250
- ◇ seat material EPDM, FPM
- ◇ disc material Al-bronze

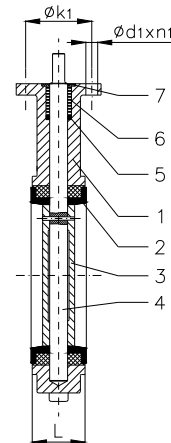
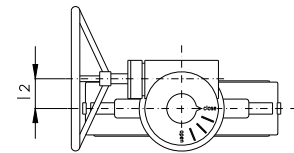
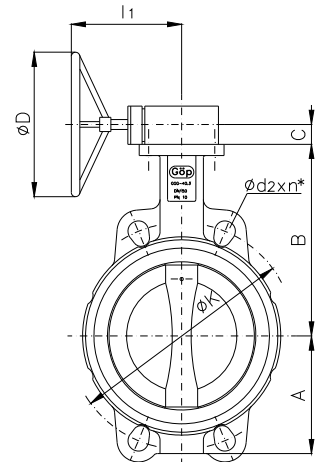

Teil Part	Bezeichnung Name	Werkstoff nach DIN Material acc. to DIN	Werkstoff nach ANSI Material acc. to ANSI
1	Gehäuse / body	EN-GJS-400-18-LT	---
2	Sitz / seat	NBR	---
3	Klappenscheibe / disc	GX5CrNiMo 19-11-2	CF-8M (ACI)
4	Welle / shaft	X6CrNiMoTi 17-12-2	316 Ti (AISI)
5	Dichtring / sealing ring	NBR	---
6	Buchse / bushing	Azetal	---
7	Unterlegscheibe / washer	Bronze	---

Flansch / flange

DN	PN 6			PN10			PN16			L	I 1	I 2	≈ kg
	A	B	C	Ø D	Ø K x n* x Ø d2	Ø K x n* x Ø d2	Ø K x n* x Ø d2	Ø K x n* x Ø d2	Ø k1 x n1 x Ø d1				
40	82	121	38	152	100 x 4 x 14	110 x 4 x 18	110 x 4 x 18	110 x 4 x 18	70 x 4 x 10	33	154	45	6,6
50	80	124	38	152	110 x 4 x 14	125 x 4 x 18	125 x 4 x 18	125 x 4 x 18	70 x 4 x 10	43	154	45	7,2
65	89	134	38	152	130 x 4 x 14	145 x 4 x 18	145 x 4 x 18	145 x 4 x 18	70 x 4 x 10	46	154	45	7,5
80	95	141	39	300	150 x 4 x 18	160 x 8 x 18	160 x 8 x 18	160 x 8 x 18	70 x 4 x 10	46	238	63	16,3
100	114	156	39	300	170 x 4 x 18	180 x 8 x 18	180 x 8 x 18	180 x 8 x 18	70 x 4 x 10	52	238	63	17,7
125	127	170	39	300	200 x 8 x 18	210 x 8 x 18	210 x 8 x 18	210 x 8 x 18	70 x 4 x 10	56	238	63	19,9
150	140	186	39	300	225 x 8 x 18	240 x 8 x 22	240 x 8 x 22	240 x 8 x 22	70 x 4 x 10	56	238	63	20,8
200	175	218	45	300	280 x 8 x 18	295 x 8 x 22	295 x 12 x 22	295 x 12 x 22	102 x 4 x 12	60	222	78	27,9
250	220	249	45	300	335 x 12 x 18	350 x 12 x 22	355 x 12 x 26	355 x 12 x 26	102 x 4 x 12	68	222	78	32,4
300	255	285	45	300	395 x 12 x 22	400 x 12 x 22	410 x 12 x 26	410 x 12 x 26	125 x 4 x 14	78	222	78	44,4
350	279	320	45	300	445 x 12 x 22	460 x 16 x 26	470 x 16 x 26	470 x 16 x 26	125 x 4 x 14	92	222	78	56,4
400	305	350	50	300	495 x 16 x 22	515 x 16 x 26	525 x 16 x 30	525 x 16 x 30	165 x 4 x 22	102	300	120	85,0
450	365	380	50	300	550 x 16 x 22	565 x 20 x 26	585 x 20 x 30	585 x 20 x 30	165 x 4 x 22	114	300	120	106,0
500	371	420	64	400	600 x 20 x 22	620 x 20 x 26	650 x 20 x 33	650 x 20 x 33	165 x 4 x 22	127	350	120	174,0
600	457	470	70	400	705 x 20 x 26	725 x 20 x 30	770 x 20 x 36	770 x 20 x 36	165 x 4 x 22	154	350	120	249,0

Mögliche Getriebe-Positionen. Die Standard-Ausführung ist Typ 1. / Possible gear box positions. The standard execution is type 1.

