

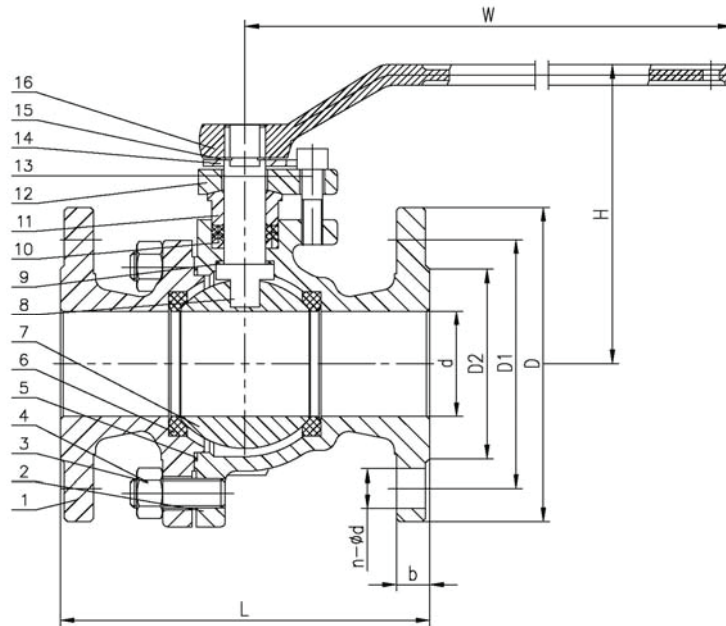

## B2002 5K FULL BORE FLANGED BALL VALVE



Main material for fittings			
Item	Fittings	Material	Mark
1	Body	Cast Bronze/Cast Iron/Cast Steel	BC6/FC200/SC230-450
2	Bonnet	Cast Bronze/Cast Iron/Cast Steel	BC6/FC200/SC230-450
3	Ball	Stainless Steel/Cast Bronze	SS304/BC6
4	Seat	PTFE/Cast Bronze	PTFE/BC6
5	Stem	Stainless Steel/Forged Brass	SS304/ C3771BD
6	Lever	Steel	SS400

Main data for flange connection mm					
Model	Face to Face	Flange Diam	Flange PCD	Flange Hole	Height
PN/DN	L	D	C	n* $\phi$	H
5K15	108	80	60	4 $\times$ $\phi$ 12	78
5K20	117	85	65	4 $\times$ $\phi$ 12	113
5K25	127	95	75	4 $\times$ $\phi$ 12	107
5K32	140	115	90	4 $\times$ $\phi$ 15	113
5K40	165	120	95	4 $\times$ $\phi$ 15	130
5K50	178	130	105	4 $\times$ $\phi$ 15	146
5K65	190	155	130	4 $\times$ $\phi$ 15	176
5K80	203	180	145	4 $\times$ $\phi$ 19	222
5K100	229	200	165	8 $\times$ $\phi$ 19	222
5K125	356	235	200	8 $\times$ $\phi$ 19	250
5K150	394	265	230	8 $\times$ $\phi$ 19	275
5K200	457	320	280	8 $\times$ $\phi$ 23	295
5K250	533	385	345	12 $\times$ $\phi$ 23	342

Design	Check	Signature	Logo	Supplier
asbsey	Chrit	Figor		PROMET VALVES AUSTRALIA
JAN.01,2013	JAN.01,2013	JAN.01,2013		